

**Thermal Printer**

**TSP200 Series**

**Programmer's Manual**





# TABLE OF CONTENTS

1. OUTLINE .....	1
2. MEMORY SWITCH AND DIP SWITCH .....	2
2-1. Memory Switch .....	2
2-2. DIP Switch .....	2
3. DISPLAY PANEL AND FUNCTIONS .....	4
3-1. LED .....	4
3-2. Switches .....	4
3-3. Switch Operation (Combined Switch Operation) .....	4
4. SERIAL INTERFACE .....	5
4-1. Interface Specifications .....	5
4-2. Interface Circuit .....	6
4-2-1. RS-232C Interface .....	6
4-3. Connectors and Signal Names .....	7
4-3-1. RS-232C Interface .....	7
4-4. Interface Connections .....	9
4-5. Data Protocol.....	10
4-5-1. DTR mode .....	10
4-5-2. X-ON/X-OFF mode .....	12
5. PARALLEL INTERFACE .....	13
5-1. Interface Specifications .....	13
5-2. Interface Timing .....	13
5-3. Connectors and Signal Names .....	14
6. PERIPHERAL UNIT DRIVE CIRCUIT .....	16
7. ERRORS .....	19
7-1. Automatic Recovery (Power Lamp: Flashing; On-Line Lamp: On).....	19
7-2. Recoverable Errors (Power Lamp: Flashing; On-Line Lamp: Off) .....	19
7-3. Fatal Error (Power Lamp: Flashing; On-Line Lamp: Flashing) .....	20
7-4. Type of buzzer sound (only Star mode) P: 50ms Pi: 100ms .....	20
8. CONTROL CODES/STAR MODE .....	21
8-1. Star Mode Command Summary .....	21
8-2. Command Specification .....	25
9. CONTROL CODES/ESC/POS MODE .....	57
10. CHARACTER CODE TABLES .....	59
11. AUTOMATIC CUTTER .....	73



# 1. OUTLINE

The TSP200 series is ideal for printing text, bar code and graphics.

The TSP200 series has the following features:

1. extremely quiet and fast printing (maximum 50 mm/sec.) using the direct line thermal printing method
2. support many bar code types  
(UPC-A, UPC-E, JAN/EAN-8, JAN/EAN-13, CODE 39, IFT 2 OF 5, CODE 128, CODE 93, NW-7)
3. dual interfaces (RS232C, Parallel)
4. memory switches that enable wide selection of printer default settings

The printer has two different software modes which can be selected using the DIP switch.

(Factory setting: Star Mode)

**Star Mode:** DIP switch 1-7 ON

This mode is compatible with Star Receipt printers, such as the SP300 and SP200 series.

**ESC/POS Mode:** DIP switch 1-7 OFF

This mode is compatible with the printers supporting ESC/POS command.

ESC/POS is a trademark of Seiko Epson Corporation.

For improvement purposes, the descriptions and specifications in this manual are subject to change without notice.

## 2. MEMORY SWITCH AND DIP SWITCH

Functional settings are made using the printer's EEPROM memory switches and the DIP switches.

### 2-1. Memory Switch

Each memory switch is a 16-bit word stored in EEPROM.

The printer is shipped with the factory setting which is made in accordance with its product type.

For the detailed functions and the settings of the Memory switches, please refer to "Chapter 8".

The factory settings are shown in the table below.

Memory switch	TSP212	TSP242
#0	0000	0000
#1	0000	0000
#2	0000	0100
#3	0000	0000
#4	0000	0000

### 2-2. DIP Switch

Be sure to turn off the power of the printer before changing the setting of the DIP switches.

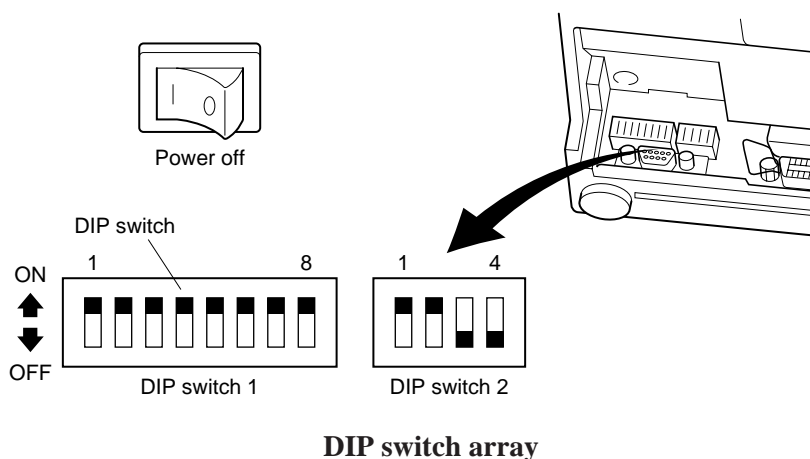

### DIP switch #1

The factory settings of DIP switch 1 are all on.

Switch	Contents	ON	OFF
1-1 1-2	Baud Rate		
1-3			
1-4	Parity Check	Disabled	Enabled
1-5	Parity Selection	Odd	Even
1-6	Handshake	DTR	XON/XOFF
1-7	Operating Mode	Star	ESC/POS
1-8	Interface	RS232C	Parallel

Baud Rate	1-1	1-2
2400BPS	OFF	OFF
4800BPS	ON	OFF
9600BPS	ON	ON
19200BPS	OFF	ON

### DIP Switch #2

Factory settings: 2-1 and 2-2 are on; 2-3 and 2-4 are off.

Switch	Contents	ON	OFF
2-1 2-2	Print Density		
2-3			
2-4	Serial I/F No. 8 Pin Reset Signal	Enabled	Disabled

Print Density	2-1	2-2
Light	OFF	OFF
Standard	ON	ON
Somewhat Heavy	ON	OFF
Heavy	OFF	ON

## 3. DISPLAY PANEL AND FUNCTIONS

### 3-1. LED

LED	Function
POWER	Lights up when the printer is turned on. Blinks when an error occurs (Refer to 7. ERRORS.)
ON LINE	Lights up when the printer is on line; goes off when the printer is off line or error occurs (Refer to 7. ERRORS.)

### 3-2. Switches

Switch	Function
ON LINE	Switches between on line and off line
FEED	Feeds the paper while pressed

### 3-3. Switch Operation (Combined Switch Operation)

1) <SELF PRINTING>

**FEED** + **POWER ON** (Turn the power on while holding the FEED switch depressed.)

Self-printing will be performed. VER. NO., Memory switch settings, DIP switch settings and character order will be printed out.

2) <Hexadecimal dump mode>

**ON LINE** + **POWER ON** (Turn the power on while holding the ON LINE switch depressed.)

Each of the signals sent from the computer to the printer will be printed out in hexadecimal code.

This function allows you to check if a control code sent to the printer by the program being used is correct or not. The last line is not printed if its data is less than one full line. However, if the ON LINE switch is pressed to set the off line mode, the last line will be printed. To turn off the mode, it is necessary to turn off the printer completely.



# 4. SERIAL INTERFACE

## 4-1. Interface Specifications

Transmission type ..... Asynchronous serial interface

Baud rate (bps) ..... 2400, 4800, 9600, or 19200  
(Selected by DIP switch)

### Word format

Start bit: ..... 1

Data bits: ..... 7 or 8 (Selected by DIP switch)

Parity: ..... Odd, Even, or None  
(Selected by DIP switch)

Stop bit: ..... 1

### Signal polarities

RS-232C ..... Mark = Logic "1" (-3V to -15V)

Space = Logic "0" (+3V to +15V)

Handshaking ..... DTR or XON/XOFF mode (Selected by DIP switch)

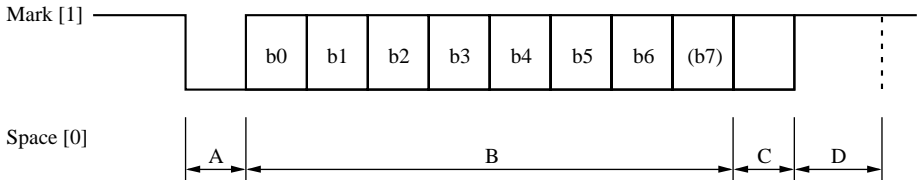

A: Start bit  
B: Data bits  
C: Vertical parity bit  
D: Stop bit

## 4-2. Interface Circuit

### 4-2-1. RS-232C Interface

Input (RXD, DSR)

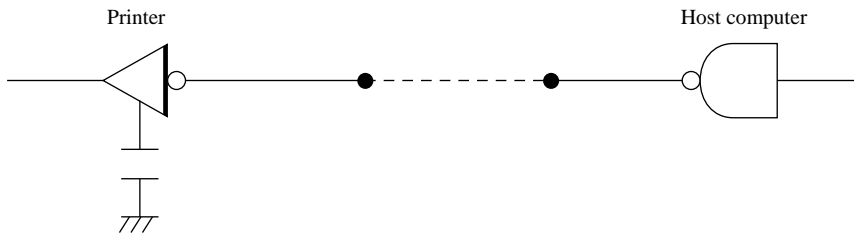

Output (DTR, FAULT, TXD, RTS)

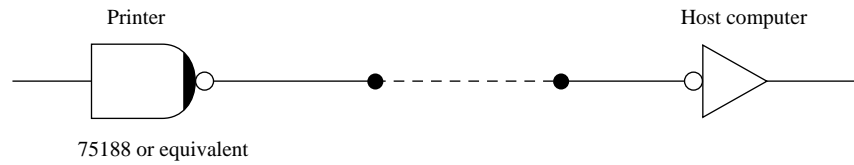

### 4-3. Connectors and Signal Names

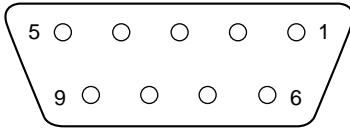

#### 4-3-1. RS-232C Interface

Pin No.	Signal name	Direction	Function																													
1	FG	–	Frame ground																													
2	RXD	IN	Receiving data																													
3	TXD	OUT	Transmission data																													
4	DTR	OUT	<p>ESC/POS mode</p> <p>1) DTR/DSR communication mode Indicates if printer is busy or not. Space: Printer ready Mark: Printer busy The conditions for busy will vary according to the memory switch settings.</p> <table border="1"> <thead> <tr> <th rowspan="2">Printer Status</th> <th colspan="2">Memory SW #4-4</th> </tr> <tr> <th>1</th> <th>0</th> </tr> </thead> <tbody> <tr> <td>1. From when the power is turned on or I/F reset until communication possible</td> <td>BUSY</td> <td>BUSY</td> </tr> <tr> <td>2. Test printing</td> <td>BUSY</td> <td>BUSY</td> </tr> <tr> <td>3. Cover open</td> <td>---</td> <td>BUSY</td> </tr> <tr> <td>4. Paper feed by paper feed switch</td> <td>---</td> <td>BUSY</td> </tr> <tr> <td>5. Stop due to no paper</td> <td>---</td> <td>BUSY</td> </tr> <tr> <td>6. During waiting for switch input in macro execution</td> <td>---</td> <td>BUSY</td> </tr> <tr> <td>7. Other errors</td> <td>---</td> <td>BUSY</td> </tr> <tr> <td>8. Receiving buffer full</td> <td>BUSY</td> <td>BUSY</td> </tr> </tbody> </table> <p>2) XON/XOFF Communication mode Indicates when printer can receive data from host. This is space, except for the following.</p> <ol style="list-style-type: none"> <li>After reset until communication possible.</li> <li>During test printing.</li> </ol>	Printer Status	Memory SW #4-4		1	0	1. From when the power is turned on or I/F reset until communication possible	BUSY	BUSY	2. Test printing	BUSY	BUSY	3. Cover open	---	BUSY	4. Paper feed by paper feed switch	---	BUSY	5. Stop due to no paper	---	BUSY	6. During waiting for switch input in macro execution	---	BUSY	7. Other errors	---	BUSY	8. Receiving buffer full	BUSY	BUSY
Printer Status	Memory SW #4-4																															
	1	0																														
1. From when the power is turned on or I/F reset until communication possible	BUSY	BUSY																														
2. Test printing	BUSY	BUSY																														
3. Cover open	---	BUSY																														
4. Paper feed by paper feed switch	---	BUSY																														
5. Stop due to no paper	---	BUSY																														
6. During waiting for switch input in macro execution	---	BUSY																														
7. Other errors	---	BUSY																														
8. Receiving buffer full	BUSY	BUSY																														

Pin No.	Signal name	Direction	Function
			Star mode Data terminal ready signal. When the printer is ready to receive data, this signal changes to "SPACE".
5	SG	—	Signal ground
6	DSR	IN	Signal line that indicates whether the host can receive data Space : Host can receive data Mark : Host cannot receive data Does not confirm the status of this signal in XON/XOFF communication or STAR mode. This signal line can be used as an external reset signal by setting the DIP switches. A pulse width of 1 ms or more mark state activates reset.
7	RTS	OUT	Same as DTR signal.
8	INIT	IN	This signal line can be used as an external reset signal by setting the DIP switches. A pulse width of 1 ms or more space state activates reset.
9	FAULT	OUT	In the Star mode, the printer will enter the mark state during the following errors: no paper, head up, cutter error. In ESC/POS mode, this is normally space.

## 4-4. Interface Connections

Refer to the host computer's interface specifications for details of how to connect the interface. The following illustrations show typical connection configurations.

[RS-232C]

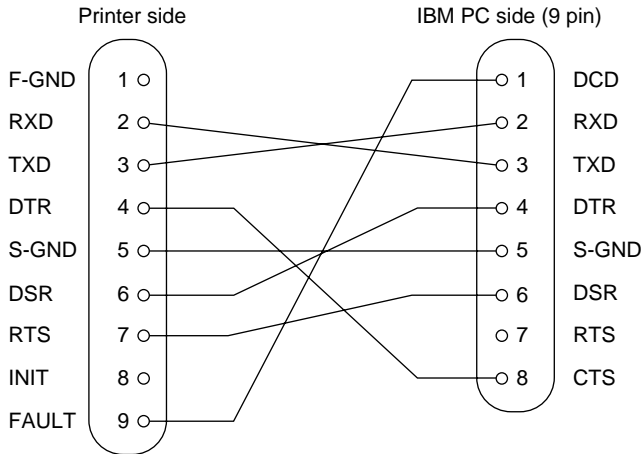
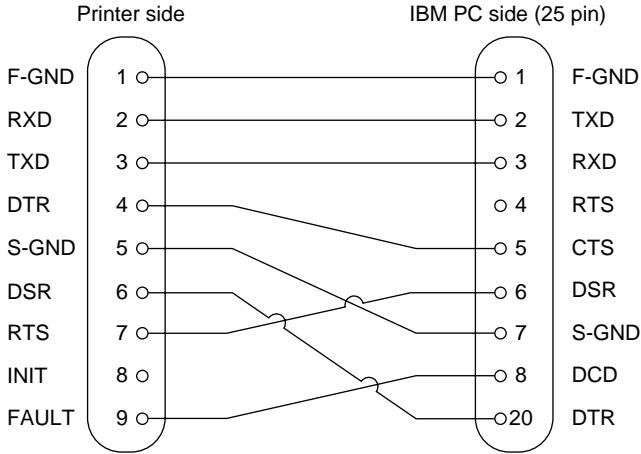

## 4-5. Data Protocol

### 4-5-1. DTR mode

This mode is accessed when the DIP switch 1-6 is set to ON. Signals are controlled using the DTR line as a BUSY flag.

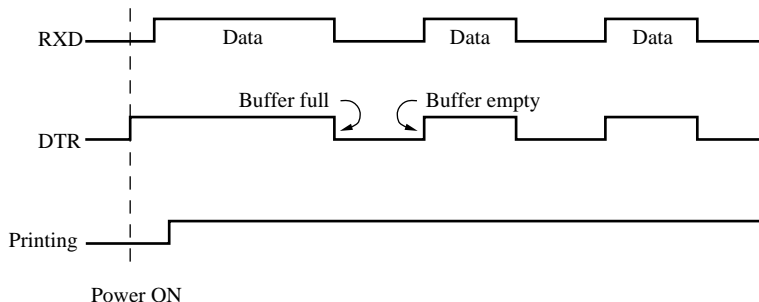

Immediately after power on (provided that no error occurs), the printer sets DTR to “SPACE” to indicate that it is ready to receive data. When the host detects that DTR is in “SPACE” condition, it begins sending text data over the RXD line.

When the printer’s remaining buffer space falls to \*256 bytes or less, the printer sets DTR to “MARK.” The host responds by halting the data transfer. However, note that the printer remains capable of receiving data until the buffer becomes full.

Available buffer space increases as the printer prints the buffered data. When the printer has cleared all but the last \*256 bytes of data, it sets DTR back to “SPACE” to indicate that it is ready to receive more data.

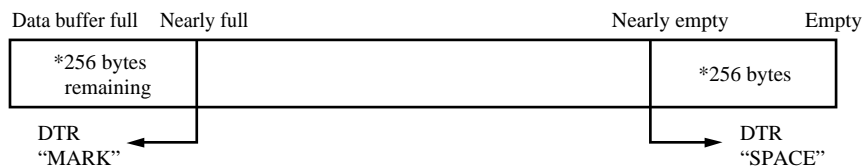

\* 16 bytes when the buffer size is set to 45 bytes

■ Error Condition

Upon detecting an error, the printer immediately sets DTR to “MARK” and goes offline. If the error was caused by a paper-out condition, you can clear it by loading new paper and then pressing the ON LINE switch (Star mode) or closing the cover (ESC/POS mode).

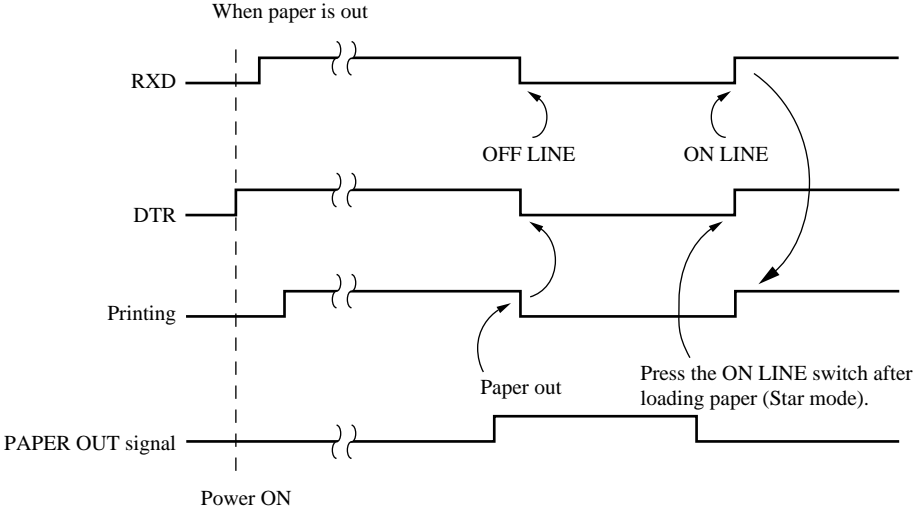

## 4-5-2. X-ON/X-OFF mode

This mode is accessed when DIP switch 1-6 is set to OFF.

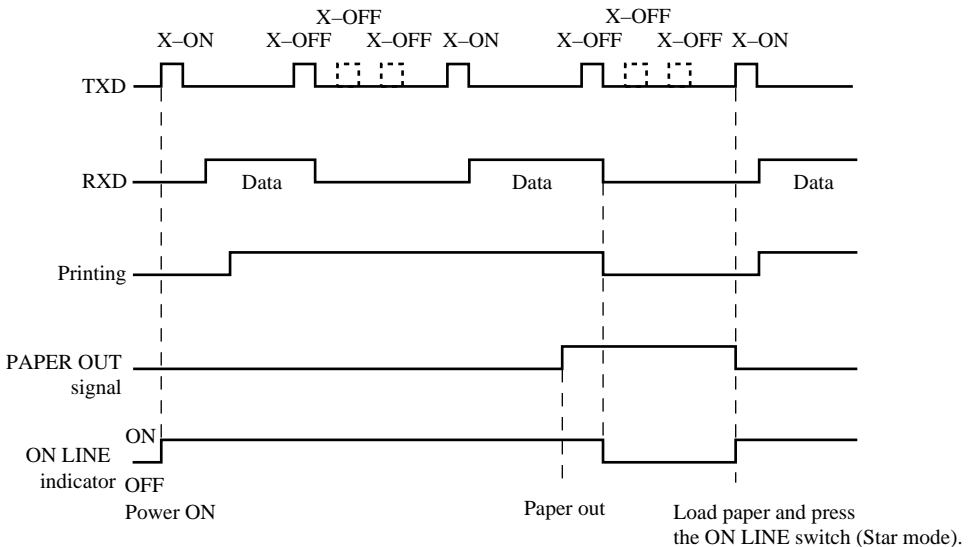

Immediately after power on (provided that no error occurs), the printer informs the host that it is ready to receive data by outputting the X-ON signal (control code DC1; value = 11H) over the TXD line. If necessary the printer repeats the signal every three seconds until the host begins sending text data over the RXD line.

When the printer's remaining buffer space falls to \*256 bytes or less, the printer begins to output X-OFF signals (DC3, value = 13H) over the TXD line. The host responds by halting the data transfer. Note that the printer remains capable of receiving data until the buffer becomes full.

Available buffer space increases as the printer prints the buffered data. When the printer has cleared all but the last \*256 bytes of data, it again outputs the X-ON signal.

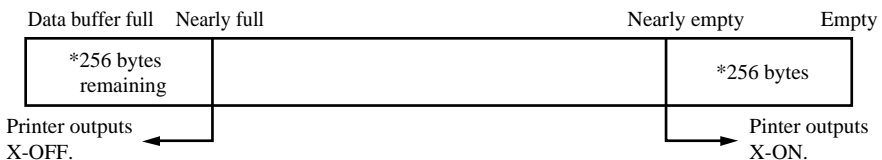

\* 16 bytes when the buffer size is set to 45 bytes



# 5. PARALLEL INTERFACE

## 5-1. Interface Specifications

Interface:	Conforms with Centronics parallel interface standard
Data transfer speed:	1000 ~ 5000 CPS
Synchronization:	External strobe pulse
Handshaking:	Using ACK and BUSY
Logic level:	TTL-level compatible

## 5-2. Interface Timing

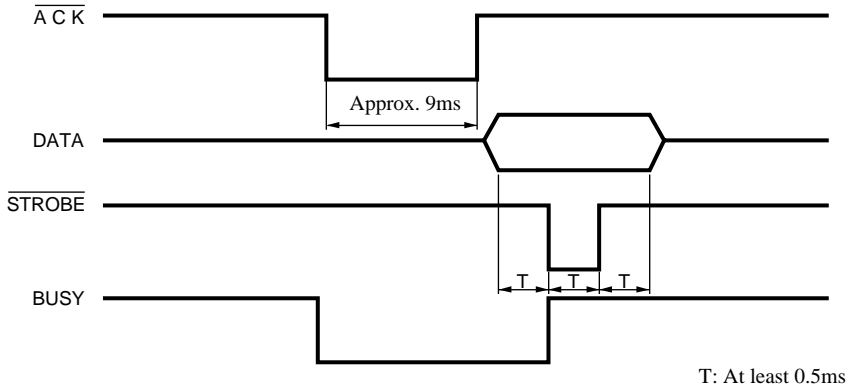

	Signal Name	Sample Circuit
Input	DATA 1 ? DATA 8	
	$\overline{\text{STROBE}}$	
Output	$\overline{\text{BUSY}}$ $\overline{\text{ACK}}$	

### 5-3. Connectors and Signal Names

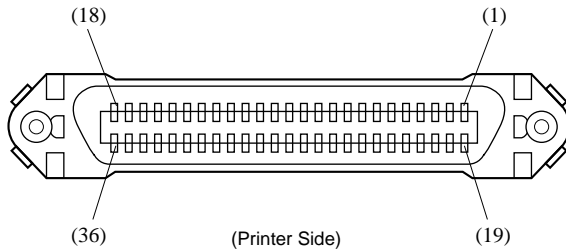

Conforms to Amphenol connector 57-30360

**Figure 5-1. Parallel Interface Connector**

Pin no	Signal name	Direction	Function
1	$\overline{\text{STROBE}}$	IN	Strobe pulse for data read. Usually HIGH; goes LOW to trigger data read.
2-9	DATA 1~8	IN	Parallel data lines for eight-bit data. HIGH is “1”; LOW is “0”.
10	$\overline{\text{ACK}}$	OUT	Printer outputs this pulse for approximately 9 $\mu$ s to indicate that data read is completed. Printer becomes ready to receive new data at the moment the ACK pulse ends.
11	BUSY	OUT	DC-level signal indicating printer’s current status. LOW indicates that printer is ready to receive the next data; HIGH indicates that printer is unable to receive.
12	PAPER OUT	OUT	DC-level signal indicating whether printer has paper. The signal stays LOW while paper is present; it goes HIGH to indicate that paper has run out.
13	SELECTED	OUT	DC-level signal; stays HIGH while printer is online.
14-15	N/C		Not used
16	SIGNAL GND		Signal ground
17	CHASSIS GND		Printer-frame ground
18	+5V		Outputs +5V (Max. 50mA)
19-30	TWISTED PAIR RETURN		Return pins for various signals. Each pin is connected to the corresponding signal line by twisted pair line.
31	$\overline{\text{RESET}}$	IN	LOW level causes printer to reset its control circuitry and return to its initial state.
32	$\overline{\text{ERROR}}$	OUT	Goes LOW to indicate that printer is unable to print.
33	EXT GND		Ground terminal for external connection
34-35	N/C		Not used
36	–	–	Fixed “HIGH” at printer side

## 6. PERIPHERAL UNIT DRIVE CIRCUIT

A drive circuit for driving peripheral units (such as cash drawers) is featured on the main logic board of this printer. A modular connector for driving peripheral units is featured on the output side on the drive circuit. When using this circuit, connect the cable for the peripheral unit. (Cables must be prepared by the user.)

Use cables which meet the following specifications.

1. Use the modular plug as shown in Figure 6-1.
2. Separate ground wire is required for Europe only.
3. If the printer is to be used in Europe, the noise filter should be attached to the cable, as shown in Figure 6-2.

**CAUTION:** DO NOT connect any other plug to the peripheral unit connector.

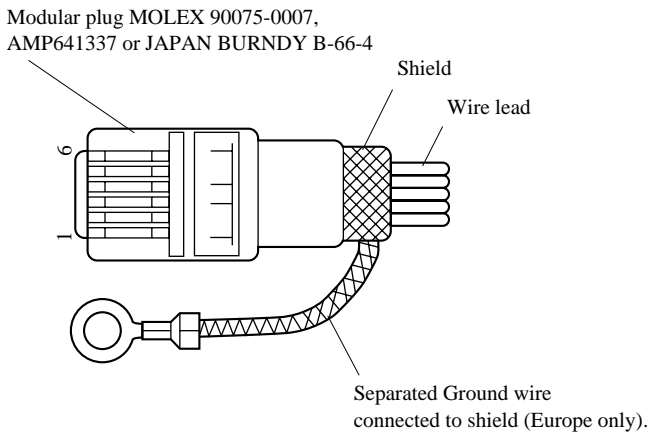

**Figure 6-1. Cable specifications for peripheral unit.**

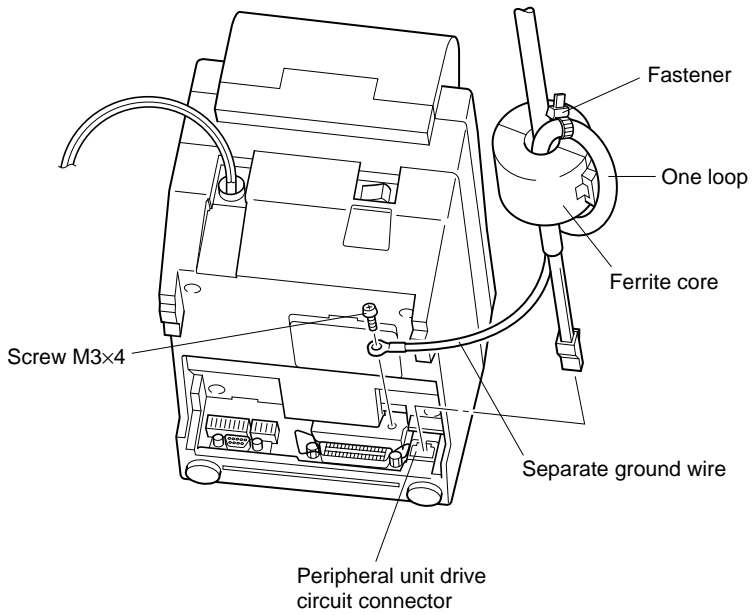
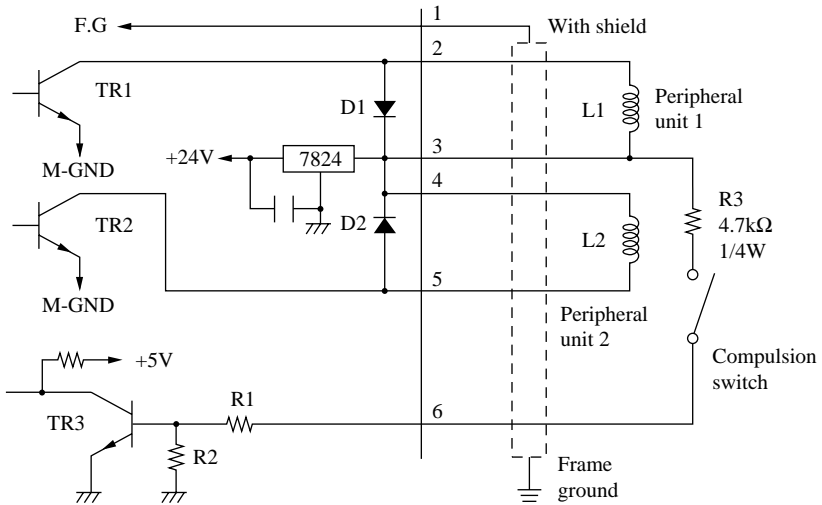

**Figure 6-2. Separate ground wire and noise filter are required for Europe.**

## ■ Drive circuit

The recommended drive circuit is shown.

[Drive output 24V, max. 1.0 A]



### NOTES:

1. Peripheral units #1 and #2 cannot be driven simultaneously.  
When driving a device continuously, do not use drive duty above 20%.
2. Compulsion switch status is available as status data.
3. Resistance for coils L1 and L2 is not less than 24 ohms.
4. Absolute maximum ratings for diodes D1 and D2 (at  $T_a=25^\circ\text{C}$ ):  
Average rectified current  $I_o = 1\text{A}$   
Maximum forward surge current (60Hz, 1-cycle sine wave)  $I_{FSM}=40\text{A}$
5. Absolute maximum rating for transistors TR1 and TR2 (at  $T_a = 25^\circ\text{C}$ ):  
Collector current  $I_c = 2\text{A}$

# 7. ERRORS

The various types of errors can be identified by the buzzer's sound and the lit LEDs.

Buzzer: The circled numbers refer to “7-4. Type of buzzer sound”.

## 7-1. Automatic Recovery (Power Lamp: Flashing; On-Line Lamp: On)

Error Description	Power Lamp Flashing Pattern	Recovery Conditions
Abnormal head temperature		Automatic recovery after head temperature lowers

## 7-2. Recoverable Errors (Power Lamp: Flashing; On-Line Lamp: Off)

upper: Star mode  
lower: ESC/POS mode

Error Description	Power Lamp Flashing Pattern	Recovery Conditions
No paper		Insert paper and press on-line switch.
		Insert paper and close cover.
Head up		Lower head and press on-line switch.
		Lower head and close cover.
Paper near end of roll		Press on-line switch and printing will continue. Both lamps light when printing and power lamp flashes and on-line lamp lights when on line.
		Same as no paper
Cover is open		Close cover and press on-line switch.
		Close cover.
Error during paper cutting		If the blade is at the home position, press the on-line switch for printing to continue. If the blade is not at the home position, it is not a recoverable error.
		Command

### 7-3. Fatal Error (Power Lamp: Flashing; On-Line Lamp: Flashing)

The unit will have to be repaired.

### 7-4. Type of buzzer sound (only Star mode) P: 50ms Pi: 100ms

① Online, Offline	P
② No Paper	PPPP PPPP
③ Head Up	PiPiPi
④ Near End	PP PP
⑤ Cover Open	PPPP
⑥ Cutter Error	Pi PPP PPiPiP P PPPPi PiPiPiPiPi PiPiPiPiPi
⑦ Buzzer by command	Pi



# 8. CONTROL CODES/STAR MODE

## 8-1. Star Mode Command Summary

The details of each command are shown in the following sections.

### Commands to Select Characters

Control codes	Hexadecimal codes	Function	Page
<ESC> “R” <i>n</i>	1B 52 <i>n</i>	Select international character set	25
<ESC> “/” “1” <ESC> “/” <1>	1B 2F 31 1B 2F 01	Select slash zero	25
<ESC> “/” “0” <ESC> “/” <0>	1B 2F 30 1B 2F 00	Select normal zero	25
<ESC> “b” <i>n1 n2 n3 n4</i> <i>d1 ... &lt;RS&gt;</i>	1B 62 <i>n1 n2 n3 n4</i> <i>d1 ... 1E</i>	Select bar code printing	26
<ESC> “M”	1B 4D	Select 12-dot pitch printing	30
<ESC> “p”	1B 70	Select 14-dot pitch printing	30
<ESC> “P”	1B 50	Select 15-dot pitch printing	30
<ESC> “.”	1B 3A	Select 16-dot pitch printing	30
<ESC> <SP> <i>n</i>	1B 20 <i>n</i>	Set character spacing	30
<SO>	0E	Sets the printing magnified double in character width.	31
<DC4>	14	Resets the printing magnified in character width.	31
<ESC> “W” <i>n</i>	1B 57 <i>n</i>	Sets the magnification rate in character width.	31
<ESC> <SO>	1B 0E	Sets the printing magnified double in character height.	31
<ESC> <DC4>	1B 14	Resets the printing magnified in character height.	31
<ESC> “h” <i>n</i>	1B 68 <i>n</i>	Sets the magnification rate in character height.	32
<ESC> “i” <i>n1 n2</i>	1B 69 <i>n1 n2</i>	Sets the magnification rates in character width and height.	32
<ESC> “_” “1” <ESC> “_” <1>	1B 2D 31 1B 2D 01	Select underlining	32
<ESC> “_” “0” <ESC> “_” <0>	1B 2D 30 1B 2D 00	Cancel underlining	32
<ESC> “_” “1” <ESC> “_” <1>	1B 5F 31 1B 5F 01	Select upperlining	33
<ESC> “_” “0” <ESC> “_” <0>	1B 5F 30 1B 5F 00	Cancel upperlining	33

Control codes	Hexadecimal codes	Function	Page
<ESC> “4”	1B 34	Select highlight printing	33
<ESC> “5”	1B 35	Cancel highlight printing	33
<SI>	0F	Inverted printing	33
<DC2>	12	Cancel inverted printing	33
<ESC> “E”	1B 45	Select emphasized printing	34
<ESC> “G”	1B 47		
<ESC> “F”	1B 46	Cancel emphasized printing	34
<ESC> “H”	1B 48		

## Commands to Set the Page Format

Control codes	Hexadecimal codes	Function	Page
<ESC> “C” <i>n</i>	1B 43 <i>n</i>	Set page length in lines	35
<ESC> “C” <0> <i>n</i>	1B 43 00 <i>n</i>	Set page length in inches	35
<ESC> “N” <i>n</i>	1B 4E <i>n</i>	Set bottom margin	35
<ESC> “O”	1B 4F	Cancel bottom margin	35
<ESC> “I” <i>n</i>	1B 6C <i>n</i>	Set left margin	36
<ESC> “Q” <i>n</i>	1B 51 <i>n</i>	Set right margin	36

## Commands to Move the Print Position

Control codes	Hexadecimal codes	Function	Page
<LF>	0A	Line feed	37
<CR>	0D	Carriage Return	37
<ESC> “a” <i>n</i>	1B 61 <i>n</i>	Feed paper <i>n</i> lines	37
<FF>	0C	Form feed	37
<HT>	09	Horizontal tab	37
<VT>	0B	Vertical tab	38
<ESC> “z” “1”	1B 7A 31	Set line spacing to 4 mm	38
<ESC> “z” <1>	1B 7A 01		
<ESC> “0”	1B 30	Set line spacing to 3 mm	38
<ESC> “J” <i>n</i>	1B 4A <i>n</i>	One time <i>n</i> /4 mm feed	38
<ESC> “j” <i>n</i>	1B 6A <i>n</i>	One time <i>n</i> /4 mm backfeed	39
<ESC> “I” <i>n</i>	1B 49 <i>n</i>	One time <i>n</i> /8 mm feed	39
<ESC> “B” <i>n1 n2 ... &lt;0&gt;</i>	1B 42 <i>n1 n2 ... 00</i>	Set vertical tab stops	39
<ESC> “D” <i>n1 n2 ... &lt;0&gt;</i>	1B 44 <i>n1 n2 ... 00</i>	Set horizontal tab stops	40

## Commands to Print Dot Graphics

Control codes	Hexadecimal codes	Function	Page
<ESC> “K” <i>n</i> <0> <i>m1 m2 ...</i>	1B 4B <i>n</i> 00 <i>m1 m2 ...</i>	Print normal density graphics	41
<ESC> “L” <i>n1 n2 m1 m2 ...</i>	1B 4C <i>n1 n2 m1 m2 ...</i>	Print high density graphics	43
<ESC> “k” <i>n</i> <0> <i>d1 ...</i>	1B 6B <i>n</i> 00 <i>d1 ...</i>	Print fine density graphics	44
<ESC> “X” <i>n1 n2 m1 ...</i>	1B 58 <i>n1 n2 d1 ...</i>	Print fine density graphics	47

## Commands to Print Download Characters

Control codes	Hexadecimal codes	Function	Page
<ESC> “&” <1> <1> <i>n m1 m2 ... m48</i>	1B 26 01 01 <i>n m1 m2 ... m48</i>	Define download character	48
<ESC> “&” “1” “1” <i>n m1 m2 ... m48</i>	1B 26 31 31 <i>n m1 m2 ... m48</i>		
<ESC> “&” <1> <0> <i>n</i>	1B 26 01 00 <i>n</i>	Delete a download character	49
<ESC> “&” “1” “0” <i>n</i>	1B 26 31 30 <i>n</i>		
<ESC> “%” “1”	1B 25 31	Enable download character set	49
<ESC> “%” <1>	1B 25 01		
<ESC> “%” “0”	1B 25 30	Disable download character set	50
<ESC> “%” <0>	1B 25 00		

## Commands to Control Peripheral Devices

Control codes	Hexadecimal codes	Function	Page
<ESC> <BEL> <i>n1 n2</i>	1B 07 <i>n1 n2</i>	Define drive pulse width for peripheral device #1	51
<BEL>	07	Control peripheral device #1	51
<FS>	1C	Control peripheral device #1 immediately	51
<EM>	19	Control peripheral device #2 immediately	51
<SUB>	1A	Control peripheral device #2 immediately	51

## Commands to Control Auto Cutter

Control codes	Hexadecimal codes	Function	Page
<ESC> “d” “0”	1B 64 30	Full-cut command to the auto cutter	52
<ESC> “d” <0>	1B 64 00		
<ESC> “d” “1”	1B 64 31	Partial-cut command to the auto cutter	52
<ESC> “d” <1>	1B 64 01		

## Other Commands

Control codes	Hexadecimal codes	Function	Page
<CAN>	18	Cancel last line & Initialize printer	53
<DC3>	13	Deselect printer	53
<DC1>	11	Set select mode	53
<RS>	1E	Beep the buzzer	53
<ESC> “#N, n1 n2 n3 n4” <LF> <NUL>	1B 23 N 2C n1 n2 n3 n4 0A 00	Set memory switch	54
<ESC> “@”	1B 40	Initialize printer	55
<ENQ>	05	Enquiry	55
<ESC> “?” <LF> <NUL>	1B 3F 0A 00	Reset printer hardware	56

## 8-2. Command Specification

### Commands to Select Characters

<b>FUNCTION</b>	Select international character set
<b>CODE</b>	<ESC> “R” <i>n</i>
<b>HEX</b>	1B 52 <i>n</i>
<b>REMARKS</b>	Selects an international character set according to the value of <i>n</i> , as shown below:

<i>n</i>	Character set	<i>n</i>	Character set
0	U.S.A.	7	Spain I
1	France	8	Japan
2	Germany	9	Norway
3	England	10	Denmark II
4	Denmark I	11	Spain II
5	Sweden	12	Latin America
6	Italy		

When the value of *n* is 0 to 9, 0(00H) to 9(09H) or “0”(30H) to “9”(39H) can be set. When the value of *n* is 10 to 12, 10(0AH) to 12(0CH) or “A”(41H) to “C”(43H) can be set.

<b>FUNCTION</b>	Select zero style
<b>CODE</b>	<ESC> “/” <i>n</i>
<b>HEX</b>	1B 2F <i>n</i>
<b>REMARKS</b>	Causes subsequent zero characters to be printed with a slash when <i>n</i> is 1, and without a slash when <i>n</i> is 0. The value of <i>n</i> can be set to 0(00H) or “0”(30H), or 1(01H) or “1”(31H).

<b>FUNCTION</b>	Select bar code printing
<b>CODE</b>	<ESC> “b” <i>n1 n2 n3 n4 di ... dk</i> <RS>
<b>HEX</b>	1B 62 <i>n1 n2 n3 n4 di ... dk</i> 1E
<b>REMARKS</b>	Prints bar code according to the value of <i>n1</i> , as shown below:

*n1*: Type of bar code

- |   |            |
|---|------------|
| 0 | UPC-E      |
| 1 | UPC-A      |
| 2 | JAN/EAN-8  |
| 3 | JAN/EAN-13 |
| 4 | CODE 39    |
| 5 | ITF        |
| 6 | CODE 128   |
| 7 | CODE 93    |
| 8 | NW-7       |

The value of *n1* can be set to 0(00H) or 8(08H) or “0”(30H) to “8”(38H).

*n2*: Printing character below bar code or line feed

- |   |   |
|---|---|
| 1 | Character below bar code is not printed, Line feed is performed after execution of command.     |
| 2 | Character below bar code is printed, Line feed is performed after execution of command.         |
| 3 | Character below bar code is not printed, Line feed is not performed after execution of command. |
| 4 | Character below bar code is printed, Line feed is not performed after execution of command.     |

The value of *n2* can be set to 1(01H) to 4(04H) or “1”(31H) to “4”(34H).

*n3*: Mode of bar code

UPC-E, UPC-A, JAN/EAN-8, JAN/EAN-13, CODE 128, CODE 93

- |   |                       |
|---|-----------------------|
| 1 | Minimum module 2 dots |
| 2 | Minimum module 3 dots |
| 3 | Minimum module 4 dots |

## CODE 39, NW-7, ITF

	CODE 39, NW-7	ITF
1	Narrow : wide 2:6 dots	2:5 dots
2	Narrow : wide 3:9 dots	4:10 dots
3	Narrow : wide 4:12 dots	6:15 dots
4	Narrow : wide 2:5 dots	2:4 dots
5	Narrow : wide 3:8 dots	4:8 dots
6	Narrow : wide 4:10 dots	6:12 dots
7	Narrow : wide 2:4 dots	2:6 dots
8	Narrow : wide 3:6 dots	3:9 dots
9	Narrow : wide 4:8 dots	4:12 dots

When the value of  $n3$  is UPC-E, UPC-A, JAN/EAN-8, JAN/EAN-13, CODE128 or CODE93, 1(01H) to 3(03H) or “1”(31H) to “3”(33H) can be set. When the value of  $n3$  is CODE39, NW-7 or ITF, 1(01H) to 9(09H) or “1”(31H) to “9”(39H) can be set.

$n4$ : Height of bar code

Can be up to 255 dots (31.9mm).

If the bar code height is larger than the line feed amount, the line feed amount is automatically multiplied by an integer.

$di\dots dk$ : Bar code data

UPC-E/UPC-A:  $K = 11$  (or 12)

The check digit at the 12th digit is automatically added, and ignored even if it is specified.

JAN/EAN-8:  $K = 7$  (or 8)

The check digit at the 8th digit is automatically added, and ignored even if it is specified.

JAN/EAN-13:  $K = 12$  (or 13)

The check digit at the 13th digit is automatically added, and ignored even if it is specified.

CODE39: The value of  $k$  is optional, and the maximum value also differs according to the modes (21 digits maximum in mode 7).

The start/stop code (“\*”) is automatically added.

- ITF: The value of k is optional, and the maximum value also differs according to the modes (40 digits maximum in mode 4).  
If the data is number of an odd digits, 0 is automatically added at the beginning of the data.
- CODE 128: The value of k is optional, and the maximum value also differs according to the modes and the types of character number (51 digits maximum in mode 1).  
The check character is automatically added.
- CODE93: The value of k is optional, and the maximum value also differs according to the modes and the types of character (30 digits maximum in mode 1).  
The check characters (C and K) are automatically added.
- NW-7: The value of k is optional, and the maximum value also differs according to the modes and the types of character number (29 digits maximum in mode 7).  
The start/stop code is also contained in the data (it is not automatically added).

The bar code printing start position is at the upper end of the current line.

If the bar code is positioned beyond the right margin, neither the bar code nor the character below the bar code will be printed.

#### Data of CODE 128 and CODE 93

When <LF> is used in a command, some kinds of control code cannot be sent by the host PC. The control code should be sent as the data as shown below:

- When sending the following data, express as a set of two characters.  
Express “% (25H)” as “%0 (25H30H)”.  
Add “40H - 5FH” after “%” for the control codes (00H - 1FH).  
Express the control code (7FH) as “%5(25H35H)”.  
Add “1 - 4 (31H - 34H)” after “%” for the function code.  
Add “6 - 8 (36H - 38H)” after “%” for the start code.



### 3) 2-character codes

#### Control codes

CODE	FORMAT
NUL	00H %@ 25H 40H
SOH	01H %A 25H 41H
STX	02H %B 25H 42H
ETX	03H %C 25H 43H
EOT	04H %D 25H 44H
ENQ	05H %E 25H 45H
ACK	06H %F 25H 46H
BEL	07H %G 25H 47H
BS	08H %H 25H 48H
HT	09H %I 25H 49H
LF	0AH %J 25H 4AH
VT	0BH %K 25H 4BH
FF	0CH %L 25H 4CH
CR	0DH %M 25H 4DH
SO	0EH %N 25H 4EH
SI	0FH %O 25H 4FH
DLE	10H %P 25H 50H
DC1	11H %Q 25H 51H
DC2	12H %R 25H 52H
DC3	13H %S 25H 53H
DC4	14H %T 25H 54H
NAK	15H %U 25H 55H
SYN	16H %V 25H 56H
ETB	17H %W 25H 57H
CAN	18H %X 25H 58H
EM	19H %Y 25H 59H
SUB	1AH %Z 25H 5AH
ESC	1BH %[ 25H 5BH
FC	1CH %¥ 25H 5CH
GS	1DH %] 25H 5DH
RS	1EH %^ 25H 5EH
US	1FH %_ 25H 5FH
DEL	7FH %5 25H 35H

#### Special code

CODE	FORMAT
% 25H	%0 25H 30H

#### Function codes

CODE	FORMAT
FNC1	%1 25H 31H ☆
FNC2	%2 25H 32H ☆
FNC3	%3 25H 33H ☆
FNC4	%4 25H 34H ☆

#### Start codes

CODE	FORMAT
START A	%6 25H 36H ☆
START B	%7 25H 37H ☆
START C	%8 25H 38H ☆

☆ For CODE 128 only.

<b>FUNCTION</b>	Select 12-dot pitch printing
<b>CODE</b>	<ESC> “M”
<b>HEX</b>	1B 4D
<b>REMARKS</b>	Prints 12-dot pitch characters without an extra space.

<b>FUNCTION</b>	Select 14-dot pitch printing
<b>CODE</b>	<ESC> “p”
<b>HEX</b>	1B 70
<b>REMARKS</b>	Prints 12-dot pitch characters with 2-dot spacing between characters.

<b>FUNCTION</b>	Select 15-dot pitch printing
<b>CODE</b>	<ESC> “P”
<b>HEX</b>	1B 50
<b>REMARKS</b>	Prints 12-dot pitch characters with 3-dot spacing between characters.

<b>FUNCTION</b>	Select 16-dot pitch printing
<b>CODE</b>	<ESC> “:”
<b>HEX</b>	1B 3A
<b>REMARKS</b>	Prints 12-dot pitch characters with 4-dot spacing between characters.

<b>FUNCTION</b>	Set the character spacing
<b>CODE</b>	<ESC> <SP> <i>n</i>
<b>HEX</b>	1B 20 <i>n</i>
<b>REMARKS</b>	Sets the space between characters to <i>n</i> dots, where <i>n</i> is a number from 0 to 15. When the value of <i>n</i> is 0 to 9, 0(00H) to 9(09H) or “0”(30H) to “9”(39H) can be set. When the value of <i>n</i> is 10 to 15, 10(0AH) to 15(0FH) or “A”(41H) to “F”(46H) can be set.

<b>FUNCTION</b>	Sets the printing magnified double in character width.
<b>CODE</b>	<SO>
<b>HEX</b>	0E
<b>REMARKS</b>	Prints the subsequent data including a character spacing set by <ESC><SP> <i>n</i> , magnified double in character width.

<b>FUNCTION</b>	Resets the printing magnified in character width.
<b>CODE</b>	<DC4>
<b>HEX</b>	14
<b>REMARKS</b>	Resets the printing magnified in character width set by <SO>, <ESC>“W” <i>n</i> and <ESC>“i” <i>n</i> 1 <i>n</i> 2.

<b>FUNCTION</b>	Sets the magnification rate in character width.																
<b>CODE</b>	<ESC> “W” <i>n</i>																
<b>HEX</b>	1B 57 <i>n</i>																
<b>REMARKS</b>	Prints the subsequent data including a character spacing set by <ESC><SP> <i>n</i> , magnified in character width by a rate specified by the value of <i>n</i> .																
	<table border="0"> <thead> <tr> <th><i>n</i></th> <th>Character width</th> <th><i>n</i></th> <th>Character width</th> </tr> </thead> <tbody> <tr> <td>0</td> <td>Unmagnify</td> <td>3</td> <td>Quadruple</td> </tr> <tr> <td>1</td> <td>Double</td> <td>4</td> <td>Quintuple</td> </tr> <tr> <td>2</td> <td>Triple</td> <td>5</td> <td>Sextuple</td> </tr> </tbody> </table>	<i>n</i>	Character width	<i>n</i>	Character width	0	Unmagnify	3	Quadruple	1	Double	4	Quintuple	2	Triple	5	Sextuple
<i>n</i>	Character width	<i>n</i>	Character width														
0	Unmagnify	3	Quadruple														
1	Double	4	Quintuple														
2	Triple	5	Sextuple														

The value of *n* can be set to 0(00H) to 5(05H) or “0”(30H) to “5”(35H).

<b>FUNCTION</b>	Sets the printing magnified double in character height.
<b>CODE</b>	<ESC> <SO>
<b>HEX</b>	1B 0E
<b>REMARKS</b>	Prints the subsequent data magnified double in character height.

<b>FUNCTION</b>	Resets the printing magnified in character height.
<b>CODE</b>	<ESC><DC4>
<b>HEX</b>	1B 14
<b>REMARKS</b>	Resets the printing magnified in character height set by <ESC><SO>, <ESC>“h” <i>n</i> and <ESC>“i” <i>n</i> 1 <i>n</i> 2.

**FUNCTION** Sets the magnification rate in character height.

**CODE** <ESC> “h” *n*

**HEX** 1B 68 *n*

**REMARKS** Prints the subsequent data magnified in character height by a rate specified by the value of *n*.

<i>n</i>	Character height	<i>n</i>	Character height
0	Unmagnify	3	Quadruple
1	Double	4	Quintuple
2	Triple	5	Sextuple

The value of *n* can be set to 0(00H) to 5(05H) or “0”(30H) to “5”(35H).

**FUNCTION** Sets the magnification rates in character width and height.

**CODE** <ESC> “i” *n1 n2*

**HEX** 1B 69 *n1 n2*

**REMARKS** Prints the subsequent data in the size specified by *n1*, *n2*. *n1* indicates the height magnification and *n2* indicates the width magnification.

<i>n1</i> ( <i>n2</i> ) = 0	Normal height (or width) size.
1	Double height (or width) size.
2	Triple height (or width) size.
3	Quadruple height (or width) size.
4	Quintuple height (or width) size.
5	Sextuple height (or width) size.

The values of *n1*, *n2* are 0(00H) to 5(05H) or “0”(30H)” to “5”(35H).

**FUNCTION** Underlining

**CODE** <ESC> “-” *n*

**HEX** 1B 2D *n*

**REMARKS** When the value of *n* is 1, underlines the subsequent data including a character spacing set by <ESC><SP> *n*.

The part to be skipped by the horizontal tab setting and the block graphic characters are not underlined.

Resets the underline mode when the value of *n* is 0.

The value of *n* can be set to 0(00H) or “0”(30H), or 1(01H) or “1”(31H).

<b>FUNCTION</b>	Upperlining
<b>CODE</b>	<ESC> “_” <i>n</i>
<b>HEX</b>	1B 5F <i>n</i>
<b>REMARKS</b>	When the value of <i>n</i> is 1, overlines the subsequent data including a character spacing set by <ESC><SP> <i>n</i> . The part to be skipped by the horizontal tab setting and the block graphic characters are not upperlined. Resets the upperline mode when the value of <i>n</i> is 0. The value of <i>n</i> can be set to 0(00H) or “0”(30H), or 1(01H) or “1”(31H).

<b>FUNCTION</b>	Select highlight printing
<b>CODE</b>	<ESC> “4”
<b>HEX</b>	1B 34
<b>REMARKS</b>	Prints the subsequent data including a character spacing set by <ESC><SP> <i>n</i> reversed. The part to be skipped by the horizontal tab setting is not reversed.

<b>FUNCTION</b>	Cancel highlight printing
<b>CODE</b>	<ESC> “5”
<b>HEX</b>	1B 35
<b>REMARKS</b>	Cancels highlight printing.

<b>FUNCTION</b>	Inverted printing
<b>CODE</b>	<SI>
<b>HEX</b>	0F
<b>REMARKS</b>	Causes subsequent characters to be inverted.

<b>FUNCTION</b>	Cancel inverted printing
<b>CODE</b>	<DC2>
<b>HEX</b>	12
<b>REMARKS</b>	Cancels inverted printing.

<b>FUNCTION</b>	Select emphasized printing
<b>CODE</b>	<ESC> “E”
<b>HEX</b>	1B 45
<b>CODE</b>	<ESC> “G”
<b>HEX</b>	1B 47
<b>REMARKS</b>	Causes subsequent characters to be emphasized.

<b>FUNCTION</b>	Cancel emphasized printing
<b>CODE</b>	<ESC> “F”
<b>HEX</b>	1B 46
<b>CODE</b>	<ESC> “H”
<b>HEX</b>	1B 48
<b>REMARKS</b>	Cancels emphasized printing.

## Commands to Set the Page Format

<b>FUNCTION</b>	Set page length in lines
<b>CODE</b>	<ESC> “C” <i>n</i>
<b>HEX</b>	1B 43 <i>n</i>
<b>REMARKS</b>	Sets the page length using the current line spacing, where <i>n</i> is between 1 and 127. Changing the line spacing later does not alter the physical page length. The current line becomes the top of the page. Resets the bottom margin. Default page length is 42 lines.

<b>FUNCTION</b>	Set page length in inches
<b>CODE</b>	<ESC> “C” <0> <i>n</i>
<b>HEX</b>	1B 43 00 <i>n</i>
<b>REMARKS</b>	Sets the page length to $n \times 24$ mm, where <i>n</i> is between 1 and 22. The current line becomes the top of the page. Resets the bottom margin.

<b>FUNCTION</b>	Set bottom margin
<b>CODE</b>	<ESC> “N” <i>n</i>
<b>HEX</b>	1B 4E <i>n</i>
<b>REMARKS</b>	Sets the bottom margin to <i>n</i> lines at the current line spacing, where <i>n</i> is between 0 and 127. Bottom margin is reset when you change the page length. Setting is invalid if the printing area on one page is 36 mm or less.

<b>FUNCTION</b>	Cancel bottom margin
<b>CODE</b>	<ESC> “O”
<b>HEX</b>	1B 4F
<b>REMARKS</b>	Cancels the bottom margin.

<b>FUNCTION</b>	Set left margin
<b>CODE</b>	<ESC> “I” <i>n</i>
<b>HEX</b>	1B 6C <i>n</i>
<b>REMARKS</b>	<p>Sets the left margin at column <i>n</i> (where <i>n</i> is between 0 and 255) at the current character pitch.</p> <p>The left margin does not move if the character pitch is changed later.</p> <p>Setting is invalid if the printing area for one line would be 36mm or less.</p>

<b>FUNCTION</b>	Set right margin
<b>CODE</b>	<ESC> “Q” <i>n</i>
<b>HEX</b>	1B 51 <i>n</i>
<b>REMARKS</b>	<p>Sets the right margin at column <i>n</i> (where <i>n</i> is between 1 and 255) at the current character pitch.</p> <p>The right margin does not move if the character pitch is changed later.</p> <p>Setting is invalid if column <i>n</i> is beyond the right edge of the printing area.</p> <p>Setting is invalid if the printing area for one line would be 36mm or less.</p>



## Commands to Move the Print Position

<b>FUNCTION</b>	Line feed
<b>CODE</b>	<LF>
<b>HEX</b>	0A
<b>REMARKS</b>	Prints the current line and feeds the paper to the next line.

<b>FUNCTION</b>	Carriage return
<b>CODE</b>	<CR>
<b>HEX</b>	0D
<b>REMARKS</b>	Prints the current line and feeds the paper to the next line. This command is ignored when CR code is invalid.

<b>FUNCTION</b>	Feed paper <i>n</i> lines
<b>CODE</b>	<ESC> “a” <i>n</i>
<b>HEX</b>	1B 61 <i>n</i>
<b>REMARKS</b>	Prints the current line and feeds the paper <i>n</i> lines (where <i>n</i> is between 1 and 127).

<b>FUNCTION</b>	Form feed
<b>CODE</b>	<FF>
<b>HEX</b>	0C
<b>REMARKS</b>	Feeds the paper to the top of the next page, according to the page length set by <ESC>“C” <i>n</i> or <ESC>“C”<0> <i>n</i> when memory switch 1-2 is set to 0. If memory switch 1-2 is set to 1, the paper is fed 18 mm, cut fully, and then feed back 18 mm. The print position is at the left margin in both cases.

<b>FUNCTION</b>	Horizontal tab
<b>CODE</b>	<HT>
<b>HEX</b>	09
<b>REMARKS</b>	Moves the print position to the next horizontal tab stop. Ignored if there is no next horizontal tab stop on the current line.

<b>FUNCTION</b>	Vertical tab
<b>CODE</b>	<VT>
<b>HEX</b>	0B
<b>REMARKS</b>	Prints the current line and feeds the paper to the next vertical tab stop and moves the print position to the left margin. Performs paper feed if no vertical tabs are set or if the current line is at or below the last vertical tab stop.

<b>FUNCTION</b>	Set line spacing to 4 mm
<b>CODE</b>	<ESC> “z” “1” or <ESC> “z” <1>
<b>HEX</b>	1B 7A 31 or 1B 7A 01
<b>REMARKS</b>	Sets the distance the paper advances in subsequent line feeds to 4 mm.

<b>FUNCTION</b>	Set line spacing to 3 mm
<b>CODE</b>	<ESC> “0”
<b>HEX</b>	1B 30
<b>REMARKS</b>	Sets the distance the paper advances in subsequent line feeds to 3 mm.

<b>FUNCTION</b>	One time $n/4$ mm feed
<b>CODE</b>	<ESC> “J” $n$
<b>HEX</b>	1B 4A $n$
<b>REMARKS</b>	Performs a line feed of $n/4$ mm once only. The value of $n$ is 1 to 255. Space setting for lines is not changed.

**FUNCTION** One time  $n/4$  mm backfeed

**CODE** <ESC> “j”  $n$

**HEX** 1B 6A  $n$

**REMARKS** Feeds the paper back  $n/4$ mm once only.  
The value of  $n$  is 1 to 255.  
Space setting for one line is not changed.  
This command can also feed the paper back to the page before the current page. In this case, the position of the line on the previous page is determined by the page length control.

**FUNCTION** One time  $n/8$  mm feed

**CODE** <ESC> “I”  $n$

**HEX** 1B 49  $n$

**REMARKS** Performs a line feed  $n/8$ mm once only.  
The value of  $n$  is 1 to 255.  
Space setting for lines is not changed.

**FUNCTION** Set vertical tab stops

**CODE** <ESC> “B”  $n1$   $n2$  ... <0>

**HEX** 1B 42  $n1$   $n2$  ... 00

**REMARKS** Cancels all current vertical tab stops and sets new vertical tab stops at lines  $n1$ ,  $n2$ , etc., where  $n1$ ,  $n2$ , etc. are numbers between 0 and 255. A maximum of 16 vertical tab stops can be set.  
The tab stops must be specified in ascending order; any violation of ascending order terminates the tab stop list. Standard termination is by the <0> control code.  
The vertical tab stops are set in terms of the current line spacing and do not move if the line spacing is changed later.

<b>FUNCTION</b>	Set horizontal tab stops
<b>CODE</b>	<ESC> “D” <i>n1</i> <i>n2</i> ... <0>
<b>HEX</b>	1B 44 <i>n1</i> <i>n2</i> ... 00
<b>REMARKS</b>	<p>Cancels all current horizontal tab stops and sets new tab stops at columns <i>n1</i>, <i>n2</i>, etc. at the current character pitch, where <i>n1</i>, <i>n2</i>, etc. are numbers between 1 and 255. A maximum of 16 horizontal tab stops can be set.</p> <p>The tab stops must be specified in ascending order; any violation of ascending order terminates the tab stop list. Standard termination is by the &lt;0&gt; control code.</p>

## Commands to Print Dot Graphics

<b>FUNCTION</b>	Print normal density graphics
<b>CODE</b>	<ESC> “K” <i>n</i> <0> <i>m1</i> <i>m2</i> ...
<b>HEX</b>	1B 4B <i>n</i> 00 <i>m1</i> <i>m2</i> ...
<b>REMARKS</b>	<p>Prints normal density dot graphics. The graphics image is 24 dots high and <math>n \times 3</math> dots wide. Maximum width is 576 dots.</p> <p><i>m1</i>, <i>m2</i>, ... are the dot data, each a 1-byte value from 0 to 255 representing 24 vertical dots, with the most significant bit representing the top three and the least significant bit representing the bottom three.</p> <p>The number of data bytes must be <i>n</i>.</p> <p>Dots beyond the right margin are ignored.</p>

### Relationship between image data and print dots

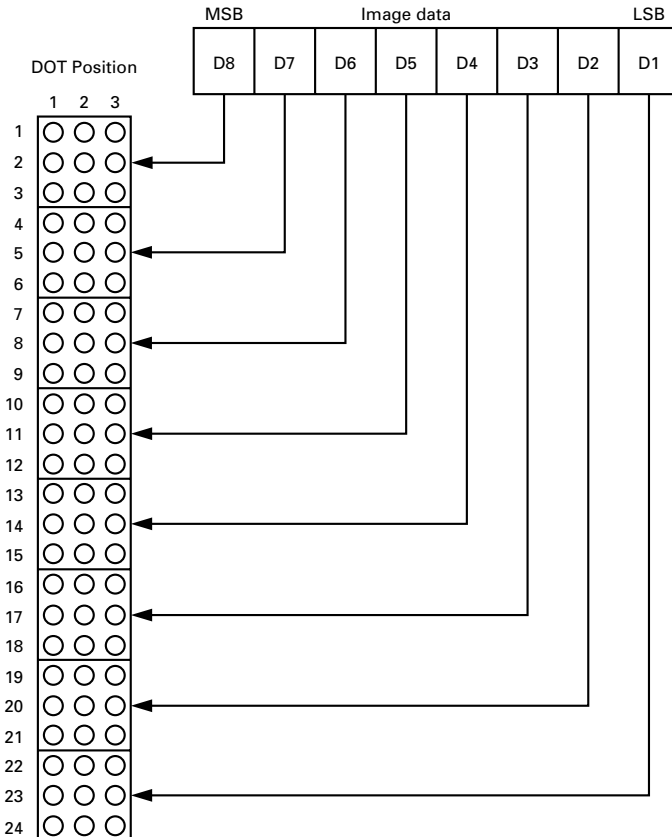

**EXAMPLE**

We will create the design below using a bit image.

	m1	m2	m3	m4	m5	m6	m7	m8	m9	m10	m11	m12	m13	m14	m15	m16	m17	m18	m19	m20	m21	m22	m23	m24	m25	m26	m27	m28	m29	m30
D8																														
D7				●		●																								
D6			●					●	●	●	●			●	●	●	●	●	●	●	●	●	●	●	●	●	●	●	●	
D5	●	●	●	●	●	●	●	●	●	●	●			●	●			●			●			●		●	●	●	●	
D4	●	●	●	●	●	●	●	●	●	●	●			●	●	●	●	●	●	●	●	●	●	●	●	●	●	●	●	
D3	●	●	●	●	●	●	●	●	●	●	●			●	●	●	●	●	●	●	●	●	●	●	●	●	●	●	●	
D2		●	●	●	●	●	●	●	●	●	●	●	●	●	●	●	●	●	●	●	●	●	●	●	●	●	●	●	●	●
D1	●			●	●			●	●						●	●									●	●				

First, since the volume of data is 30,  $nI = (1E)_H$ . If the data  $m1 \sim m30$  is converted to hexadecimal, it appears as shown below.

Data	Binary	Hexa-decimal	Data	Binary	Hexa-decimal	Data	Binary	Hexa-decimal
<i>m1</i>	00000001	01	<i>m11</i>	00111110	3E	<i>m21</i>	00111110	3E
<i>m2</i>	00011110	1E	<i>m12</i>	00000010	02	<i>m22</i>	00101110	2E
<i>m3</i>	00111110	3E	<i>m13</i>	00000010	02	<i>m23</i>	00101110	2E
<i>m4</i>	01011111	5F	<i>m14</i>	00111110	3E	<i>m24</i>	00111110	3E
<i>m5</i>	00011111	1F	<i>m15</i>	00111110	3E	<i>m25</i>	00101111	2F
<i>m6</i>	01011110	5E	<i>m16</i>	00101111	2F	<i>m26</i>	00101111	2F
<i>m7</i>	00011110	1E	<i>m17</i>	00101111	2F	<i>m27</i>	00111110	3E
<i>m8</i>	00111111	3F	<i>m18</i>	00111110	3E	<i>m28</i>	00111110	3E
<i>m9</i>	00101111	2F	<i>m19</i>	00101110	2E	<i>m29</i>	00000010	02
<i>m10</i>	00111110	3E	<i>m20</i>	00101110	2E	<i>m30</i>	00000010	02

**Printing Sample**



STAR MODE

**FUNCTION**

Print high density graphics

**CODE**

<ESC> "L" *n1 n2 m1 m2 ...*

**HEX**

1B 4C *n1 n2 m1 m2 ...*

**REMARKS**

Prints high density dot graphics. The graphics image is 24 dots high and  $n1 + n2 \times 256$  dots wide. Maximum width is 576 dots. *m1, m2, ...* are the dot data, each a 1-byte value from 0 to 255 representing 24 vertical dots, with the most significant bit representing the top three and the least significant bit representing the bottom three.

The number of data bytes must be  $n1 + n2 \times 256$ .

Dots beyond the right margin are ignored.

Relationship between image data and print dots

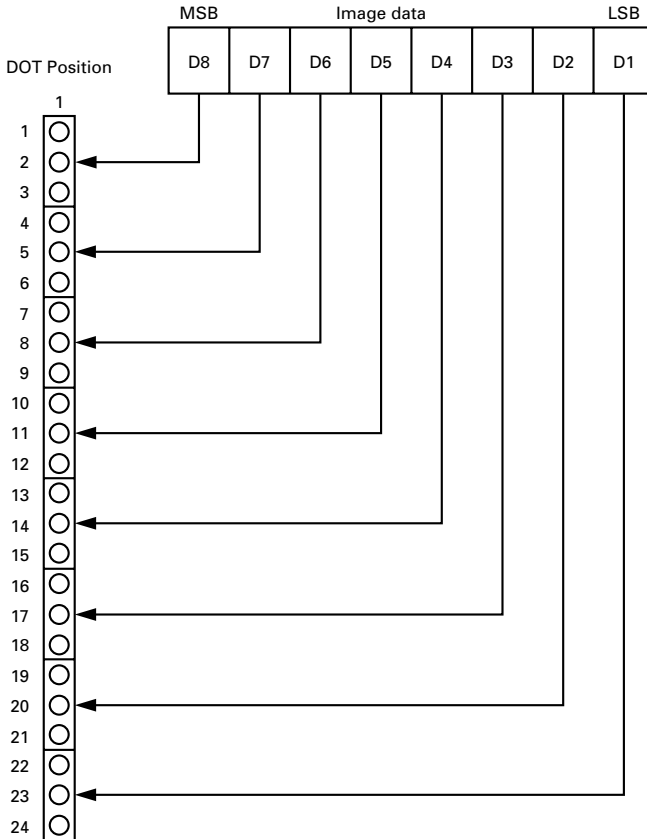

**EXAMPLE**

We will create the design below using a bit image.

	m1	m2	m3	m4	m5	m6	m7	m8	m9	m10	m11	m12	m13	m14	m15	m16	m17	m18	m19	m20	m21	m22	m23	m24	m25	m26	m27	m28	m29	m30
D8																														
D7				●		●																								
D6			●					●	●	●	●			●	●	●	●	●	●	●	●	●	●	●	●	●	●	●	●	
D5		●	●	●	●	●	●	●	●	●	●			●	●		●		●		●		●		●	●	●	●		
D4		●	●	●	●	●	●	●	●	●	●			●	●	●	●	●	●	●	●	●	●	●	●	●	●	●	●	
D3		●	●	●	●	●	●	●	●	●	●			●	●	●	●	●	●	●	●	●	●	●	●	●	●	●	●	
D2		●	●	●	●	●	●	●	●	●	●			●	●	●	●	●	●	●	●	●	●	●	●	●	●	●	●	
D1	●			●	●			●	●						●	●									●	●				

First, since the volume of data is 30,  $nI = (1E)_H$ . If the data  $m1 \sim m30$  is converted to hexadecimal, it appears as shown below.

Data	Binary	Hexa-decimal	Data	Binary	Hexa-decimal	Data	Binary	Hexa-decimal
<i>m1</i>	00000001	01	<i>m11</i>	00111110	3E	<i>m21</i>	00111110	3E
<i>m2</i>	00011110	1E	<i>m12</i>	00000010	02	<i>m22</i>	00101110	2E
<i>m3</i>	00111110	3E	<i>m13</i>	00000010	02	<i>m23</i>	00101110	2E
<i>m4</i>	01011111	5F	<i>m14</i>	00111110	3E	<i>m24</i>	00111110	3E
<i>m5</i>	00011111	1F	<i>m15</i>	00111110	3E	<i>m25</i>	00101111	2F
<i>m6</i>	01011110	5E	<i>m16</i>	00101111	2F	<i>m26</i>	00101111	2F
<i>m7</i>	00011110	1E	<i>m17</i>	00101111	2F	<i>m27</i>	00111110	3E
<i>m8</i>	00111111	3F	<i>m18</i>	00111110	3E	<i>m28</i>	00111110	3E
<i>m9</i>	00101111	2F	<i>m19</i>	00101110	2E	<i>m29</i>	00000010	02
<i>m10</i>	00111110	3E	<i>m20</i>	00101110	2E	<i>m30</i>	00000010	02

Horizontal density is three times that of the bit image for <ESC>“k”. (Compare the print samples.)

**Printing Sample**



**FUNCTION**

Print fine density bit image

**CODE**

<ESC> “k” *n* <0> *d1...dk* [ $k = n * 24$ ]

**HEX**

1B 6B *n* 00 *d1...dk* [ $k = n * 24$ ]

**REMARKS**

Prints a bit image using 1 horizontal dot and 1 vertical dot for 1 dot of input data.

*n* is designated by the number of data bytes in the horizontal direction and *n* must be within the range 1 to 72.

The data is ignored if it is longer than 72 digits or goes beyond the right margin. Relationship between the input data and actual printing is shown below.





**EXAMPLE**

**Printing Sample**

	MSB				LSB				MSB				LSB				
d1															d2		
d3			●	●	●	●	●	●	●	●	●	●	●	●	d4		
d5		●	●	●	●	●	●	●	●	●	●	●	●	●	d6		
d7	●	●	●	●	●	●	●	●	●	●	●	●	●	●	d8		
d9	●	●	●	●											d10		
d11	●	●	●	●								●	●	●	d12		
d13	●	●	●	●								●	●	●	d14		
d15				●	●	●	●	●	●	●	●				d16		
d17			●	●	●	●	●	●	●	●	●				d18		
d19			●	●	●	●	●	●	●	●	●				d20		
d21		●	●	●	●					●	●	●	●		d22		
d23		●	●	●						●	●	●			d24		
d25		●	●	●	●			●	●			●	●	●	d26		
d27		●	●	●		●	●					●	●	●	d28		
d29		●	●	●		●	●	●				●	●	●	d30		
d31	●	●	●	●		●	●			●	●	●	●	●	d32		
d33	●	●	●	●								●	●	●	d34		
d35	●	●	●	●	●			●	●			●	●	●	d36		
d37	●	●	●	●	●	●	●	●	●	●	●	●	●	●	d38		
d39	●	●	●	●	●	●	●	●	●	●	●	●	●	●	d40		
d41															d42		
d43															d44		
d45															d46		
d47															d48		



STAR MODE

Data	Binary	Hexa-decimal	Data	Binary	Hexa-decimal
d1	00000000	00	d2	00000000	00
d3	00011111	1F	d4	11111000	F8
d5	00111111	3F	d6	11111100	FC
d7	01110111	77	d8	01110111	EE
d9	11111000	F8	d10	00011111	1F
d11	11111000	F8	d12	00011111	1F
d13	11111000	F8	d14	00011111	1F
d15	00001111	0F	d16	11110000	F0
d17	00011111	1F	d18	11111000	F8
d19	00011111	1F	d20	11111000	F8
d21	00111110	3E	d22	01111100	7C
d23	00111000	38	d24	00011100	1C
d25	011111001	79	d26	10011110	9E
d27	01110011	73	d28	11001110	CE
d29	01110011	73	d30	11001110	CE
d31	11111001	F9	d32	10011111	9F
d33	11111000	F8	d34	00011111	1F
d35	11111110	FE	d36	01111111	7F
d37	11111111	FF	d38	11111111	FF
d39	11111111	FF	d40	11111111	FF
d41	00000000	00	d42	00000000	00
d43	00000000	00	d44	00000000	00
d45	00000000	00	d46	00000000	00
d47	00000000	00	d48	00000000	00

**FUNCTION** Print fine density graphics

**CODE** <ESC> “X”  $n1$   $n2$   $d1\dots d [(n1+n2*256)*3]$

**HEX** 1B 5  $n1$   $n2$   $d1\dots d [(n1+n2*256)*3]$

**REMARKS** Prints a bit image of the input data using horizontal and vertical resolutions of 8 dots/mm.

Data extending past the right margin is ignored.

The relationship between the input data and the actual printing is shown below.

$$1 \leq n1 + n2 \times 256 \leq 576$$

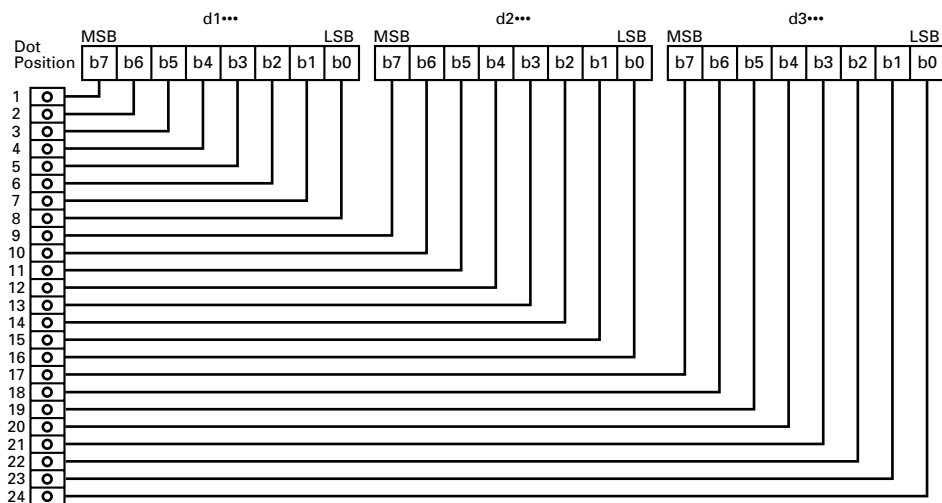

## Commands to Print Download Characters

<b>FUNCTION</b>	Define download character								
<b>CODE</b>	<ESC>	"&"	<1>	<1>	<i>n</i>	<i>m1</i>	<i>m2</i>	...	<i>m48</i>
<b>HEX</b>	1B	26	01	01	<i>n</i>	<i>m1</i>	<i>m2</i>	...	<i>m48</i>
<b>CODE</b>	<ESC>	"&"	"1"	"1"	<i>n</i>	<i>m1</i>	<i>m2</i>	...	<i>m48</i>
<b>HEX</b>	1B	26	31	31	<i>n</i>	<i>m1</i>	<i>m2</i>	...	<i>m48</i>

**REMARKS** Defines one new character and stores it in RAM for later use. *n* is the character code of the character defined and must be between 32 and 127.

If the maximum of 32 external characters have already been stored, the oldest stored external character are deleted so that new external character can be stored.

The character matrix is 12 dots wide and 24 dots high.

Relationship between the character pattern and the character data is shown below.

### EXAMPLE

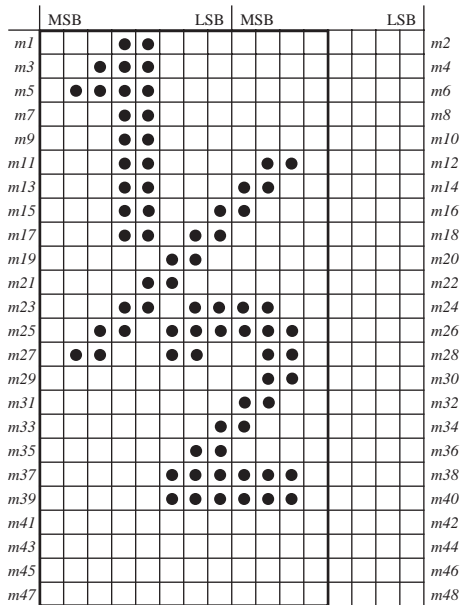

Ignored  
4 bits

Data	Binary	Hexa- decimal	Data	Binary	Hexa- decimal
<i>m1</i>	00011000	18	<i>m2</i>	00000000	00
<i>m3</i>	00111000	38	<i>m4</i>	00000000	00
<i>m5</i>	01111000	78	<i>m6</i>	00000000	00
<i>m7</i>	00011000	18	<i>m8</i>	00000000	00
<i>m9</i>	00011000	18	<i>m10</i>	00000000	00
<i>m11</i>	00011000	18	<i>m12</i>	01100000	60
<i>m13</i>	00011000	18	<i>m14</i>	11000000	C0
<i>m15</i>	00011001	19	<i>m16</i>	10000000	80
<i>m17</i>	00011011	1B	<i>m18</i>	00000000	00
<i>m19</i>	00000110	06	<i>m20</i>	00000000	00
<i>m21</i>	00001100	0C	<i>m22</i>	00000000	00
<i>m23</i>	00011011	1B	<i>m24</i>	11000000	C0
<i>m25</i>	00110111	37	<i>m26</i>	11100000	E0
<i>m27</i>	01100110	66	<i>m28</i>	01100000	60
<i>m29</i>	00000000	00	<i>m30</i>	01100000	60
<i>m31</i>	00000000	00	<i>m32</i>	11000000	C0
<i>m33</i>	00000001	01	<i>m34</i>	10000000	80
<i>m35</i>	00000011	03	<i>m36</i>	00000000	00
<i>m37</i>	00000111	07	<i>m38</i>	11100000	E0
<i>m39</i>	00000111	07	<i>m40</i>	11100000	E0
<i>m41</i>	00000000	00	<i>m42</i>	00000000	00
<i>m43</i>	00000000	00	<i>m44</i>	00000000	00
<i>m45</i>	00000000	00	<i>m46</i>	00000000	00
<i>m47</i>	00000000	00	<i>m48</i>	00000000	00

**FUNCTION** Delete a download character

**CODE** <ESC> "&" <1> <0> *n*

**HEX** 1B 26 01 00 *n*

**CODE** <ESC> "&" "1" "0" *n*

**HEX** 1B 26 31 30 *n*

**REMARKS** Deletes the download character which was assigned the value *n*.

**FUNCTION** Enable download character set

**CODE** <ESC> "%" "1" or <ESC> "%" <1>

**HEX** 1B 25 31 or 1B 25 01

**REMARKS** Enables the download character set.

**FUNCTION**

Disable download character set

**CODE**

&lt;ESC&gt; “%” “0” or &lt;ESC&gt; “%” &lt;0&gt;

**HEX**

1B 25 30 or 1B 25 00

**REMARKS**

Disables the selected download character set and returns to the built-in ROM character set.

## Commands to Control Peripheral Devices

<b>FUNCTION</b>	Define drive pulse width for peripheral device #1
<b>CODE</b>	<ESC><BEL> <i>n1</i> <i>n2</i>
<b>HEX</b>	1B 07 <i>n1</i> <i>n2</i>
<b>REMARKS</b>	Defines the drive pulse width for peripheral devices requiring other than standard 200 ms pulse time and delay time. <i>n1</i> indicates the energizing time and <i>n2</i> indicates the delay time, using 10ms units.

<b>FUNCTION</b>	Control peripheral device #1
<b>CODE</b>	<BEL>
<b>HEX</b>	07
<b>REMARKS</b>	Executes drive pulse for peripheral device #1.

<b>FUNCTION</b>	Control peripheral device #1 immediately
<b>CODE</b>	<FS>
<b>HEX</b>	1C
<b>REMARKS</b>	Executes drive pulse for peripheral device #1 immediately.

<b>FUNCTION</b>	Control peripheral device #2 immediately
<b>CODE</b>	<EM>
<b>HEX</b>	19
<b>REMARKS</b>	Drives peripheral device #2. The drive pulse width and delay time are fixed at 200 ms.

<b>FUNCTION</b>	Control peripheral device #2 immediately
<b>CODE</b>	<SUB>
<b>HEX</b>	1A
<b>REMARKS</b>	Drives peripheral device #2. The drive pulse width and delay time are fixed at 200 ms.

## Commands to Control Auto Cutter

<b>FUNCTION</b>	Full-cut command to the auto cutter
<b>CODE</b>	<ESC> “d” “0” or <ESC> “d” <0>
<b>HEX</b>	1B 64 30 or 1B 64 00
<b>REMARKS</b>	Cuts the paper fully when memory switch 2-C is set to 0. If memory switch 2-C is set to 1, the paper is fed to 18 mm and cut fully. When auto cutter is invalid, this command is not valid.

<b>FUNCTION</b>	Partial-cut command to the auto cutter
<b>CODE</b>	<ESC> “d” “1” or <ESC> “d” <1>
<b>HEX</b>	1B 64 31 or 1B 64 01
<b>REMARKS</b>	Cuts the paper partially when memory switch 2-C is set to 0. If memory switch 2-C is set to 1, the paper is fed to 18 mm and cut partially.



## Other Commands

<b>FUNCTION</b>	Cancel last line & Initialize printer
<b>CODE</b>	<CAN>
<b>HEX</b>	18
<b>REMARKS</b>	Clears the line buffer, and initializes the commands set already. Does not affect the external equipment drive conditions set by the code <ESC> <BEL> <i>n1 n2</i> . (This is the same during a mechanical error.) (Line buffer means the print data expansion area.)

<b>FUNCTION</b>	Deselect printer
<b>CODE</b>	<DC3>
<b>HEX</b>	13
<b>REMARKS</b>	Deselects the printer. The printer disregards all subsequent characters and commands except <DC1>, which activates the printer.

<b>FUNCTION</b>	Set select mode
<b>CODE</b>	<DC1>
<b>HEX</b>	(11)H
<b>REMARKS</b>	When the printer receives a <DC1> code, the deselect mode is canceled and data following this code is input to the buffer.

<b>FUNCTION</b>	Beep the buzzer
<b>CODE</b>	<RS>
<b>HEX</b>	1E
<b>REMARKS</b>	Sounds a brief beep tone.

**FUNCTION** Set memory switch

**CODE** <ESC> “# N , n1n2n3n4” <LF> <NUL>

**HEX** 1B 23 N 2C n1n2n3n4 0A 00

**REMARKS** Set the memory switch. In order to enable changed memory switch setting, turn the printer OFF and ON again or send printer reset command (<ESC> “?”) to the printer. Changed memory switch settings are stored in EEPROM and these setting will be stored as long as the time when they are changed again.

N :Memory switch number (0, 1, 2, 3, 4)

n1n2n3n4 :Mode settings (For details see below)

1) N=0

n1 :Always “0”

n2 :Always “0”

n3 :Always “0”

(Default)

○ : Available

Parameter	Setting	0	4	Star	ESC/POS
n4	FF command	Form Feed	Paper Feed, Cut & Back	○	–

2) N=1

n1 :Always “0”

n2 :Always “0”

(Default)

○ : Available

Parameter	Setting	0	1	Star	ESC/POS
n3	Zero style	Normal zero	Slashed zero	○	–
n4	International character set		See below	○	–

n4	Country
0	USA
1	France
2	Germany

n4	Country
3	UK
4	Denmark #1
5	Sweden

n4	Country
6	Italy
7	Spain #1
8	Japan

n4	Country
9	Norway
A	Denmark #2
B	Spain #2

n4	Country
C	Latin America

## 3) N=2

n3 :Always “0”

(Default)

○ : Available

Parameter	Setting	0	1	Star	ESC/POS
n1	ESC d command	Cut	Paper feed & cut	○	–
n2	Cutter	Invalid (TSP212)	Valid (TSP242)	○	○
n4	Paper near end	Invalid	Valid	○	–

## 4) N=3

n1 :Always “0” (Default)

○ : Available

Parameter	Setting	0	1	2	3	Star	ESC/POS
n2	Character table	Normal	IBM	Katakana	IBM	○	–
n3	Print column	48	38	–	–	○	–
n4	CR code	Invalid	Invalid	Same as <LF>	Same as <LF>	○	–
	Line feed (mm)	4	3	4	3		

## 5) N=4

n1 :Always “0”

(Default)

○ : Available

Parameter	Setting	0	1	Star	ESC/POS
n2	Buffer size	4 Kbytes	45 bytes	○	○
n3	Busy conditions	See 4-3-1 RS-232C Interface		–	○
n4	Data receive error	Print “?”	Ignore	–	○

**FUNCTION**

Initialize printer

**CODE**

&lt;ESC&gt; “@”

**HEX**

1B 40

**REMARKS**

Reinitializes the printer. Clears the print buffer and returns settings to their power-up values.

Does not clear the input buffer, downloaded characters, or conditions for peripheral devices.

**FUNCTION**

Enquiry

**CODE**

&lt;ENQ&gt;

**HEX**

05

**REMARKS**

Causes the printer to transmit a status byte.

# Status byte

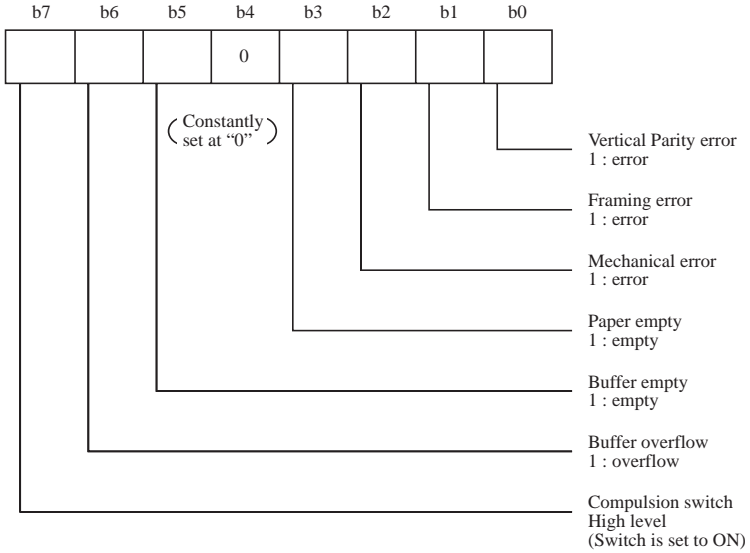

STAR MODE

<b>FUNCTION</b>	Reset the printer hardware.
<b>CODE</b>	<ESC> “?” <LF><NUL>
<b>HEX</b>	1B 3F 0A 00
<b>REMARKS</b>	Resets the printer hardware.

## 9. CONTROL CODES/ESC/POS MODE

Control Code	Hexadecimal Code	Function
HT	09	Horizontal tab
LF	0A	Print line feed
FF	0C	Page mode print and return
DLE EOT	10 04	Real time transmission of status
DLE ENQ	10 05	Real time request to printer
CAN	18	Cancel print data in page mode
ESC FF	1B FF	Print page mode data
ESC SP	1B 20	Set right space amount of character
ESC !	1B 21	Universal print mode designation
ESC #	1B 23	Set memory switch
ESC \$	1B 24	Designate absolute printing
ESC %	1B 25	Designate/cancel download character set
ESC &	1B 26	Define download characters
ESC *	1B 2A	Designate bit image mode
ESC -	1B 2D	Designate/cancel underline
ESC 2	1B 32	Set 1/6 inch line feed amount
ESC 3	1B 33	Set line feed amount
ESC =	1B 3D	Select peripheral equipment
ESC ?	1B 3F	Delete download characters
ESC @	1B 40	Initialize printer
ESC D	1B 44	Set horizontal tab position
ESC E	1B 45	Designate/cancel emphasized print
ESC G	1B 47	Designate/cancel double print
ESC J	1B 4A	Print and paper feed
ESC L	1B 4C	Select page mode
ESC R	1B 52	Select international characters
ESC S	1B 53	Select standard mode
ESC T	1B 54	Select character print direction in print mode
ESC V	1B 56	Designate/cancel 90° character rotation
ESC W	1B 57	Set print range in page mode
ESC \	1B 5C	Designate relative position
ESC a	1B 61	Align position
ESC c4	1B 63 34	Select no valid paper detector at print stop
ESC c5	1B 63 35	Enable/disable panel switch
ESC d	1B 64	Print and paper feed "n" lines
ESC i	1B 69	Partial cut (one section remaining)
ESC p	1B 70	Designate pulse generation
ESC t	1B 74	Select character code table

Control Code	Hexadecimal Code	Function
ESC u	1B 75	Transmission of peripheral equipment status
ESC v	1B 76	Transmission of paper detection status
ESC {	1B 7B	Designate/cancel inverted printing
GS !	1D 21	Designate character size
GS \$	1D 24	Designate absolute position of vertical direction of characters in page mode
GS *	1D 2A	Define download bit image
GS /	1D 2F	Print download bit image
GS :	1D 3A	Start/finish macro definition
GS B	1D 42	Designate/cancel reverse printing
GS H	1D 48	Select print position of HRI characters
GS I	1D 49	Printer ID transmission
GS L	1D 4C	Set left margin
GS P	1D 50	Set basic calculated pitch
GS V	1D 56	Paper cut
GS W	1D 57	Set print range
GS \	1D 5C	Designate the relative position of vertical characters when printing in the page mode
GS ^	1D 5E	Execute macro
GS a	1D 61	Enable/disable automatic status transmission
GS f	1D 66	Select HRI character font
GS h	1D 68	Set bar code height
GS k	1D 6B	Printing of bar code
GS r	1D 72	Transmission of status
GS w	1D 77	Set lateral size of bar code

# 10. CHARACTER CODE TABLES

## Star Mode

Hexa- decimal	0	1	2	3	4	5	6	7
0	<NUL> 0		SP 32	0 48	@ 64	P 80	` 96	p 112
1		<DC1> 17	! 33	1 49	A 65	Q 81	a 97	q 113
2		<DC2> 18	" 34	2 50	B 66	R 82	b 98	r 114
3		<DC3> 19	# 35	3 51	C 67	S 83	c 99	s 115
4		<DC4> 20	\$ 36	4 52	D 68	T 84	d 100	t 116
5	<ENQ> 5		% 37	5 53	E 69	U 85	e 101	u 117
6			& 38	6 54	F 70	V 86	f 102	v 118
7	<BEL> 7		' 39	7 55	G 71	W 87	g 103	w 119
8		<CAN> 24	( 40	8 56	H 72	X 88	h 104	x 120
9	<HT> 9	<EM> 25	) 41	9 57	I 73	Y 89	i 105	y 121
A	<LF> 10	<SUB> 26	* 42	: 58	J 74	Z 90	j 106	z 122
B	<VT> 11	<ESC> 27	+ 43	; 59	K 75	[ 91	k 107	{ 123
C	<FF> 12	<FS> 28	, 44	< 60	L 76	\ 92	l 108	 124
D	<CR> 13		- 45	= 61	M 77	] 93	m 109	} 125
E	<SO> 14	<RS> 30	. 46	> 62	N 78	^ 94	n 110	~ 126
F	<SI> 15		/ 47	? 63	O 79	- 95	o 111	⊗ 127

# Star Mode

(Character table: Normal)

Hexa-decimal	8	9	A	B	C	D	E	F
0	┆ 128	┆ 144	Ä 160	é 176	ù 192	ā 208	┆ 224	┆ 240
1	┆ 129	┆ 145	Ö 161	è 177	ū 193	â 209	┆ 225	┆ 241
2	┆ 130	┆ 146	Ü 162	ē 178	û 194	° 210	┆ 226	┆ 242
3	┆ 131	┆ 147	ß 163	ê 179	ç 195	°C 211	┆ 227	┆ 243
4	┆ 132	┆ 148	§ 164	ï 180	¿ 196	°F 212	┆ 228	┆ 244
5	┆ 133	┆ 149	a 165	í 181	ñ 197	Ω 213	┆ 229	┆ 245
6	┆ 134	┆ 150	o 166	ì 182	ņ 198	μ 214	┆ 230	┆ 246
7	┆ 135	┆ 151	f 167	ī 183	Ē 199	Σ 215	┆ 231	┆ 247
8	┆ 136	┆ 152	¢ 168	î 184	ƴ 200	σ 216	┆ 232	┆ 248
9	┆ 137	┆ 153	½ 169	ö 185	ı 201	¯ 217	┆ 233	┆ 249
A	┆ 138	┆ 154	₯ 170	ó 186	Å 202	TL 218	┆ 234	┆ 250
B	┆ 139	┆ 155	₧ 171	ò 187	φ 203	X 219	┆ 235	┆ 251
C	┆ 140	┆ 156	¥ 172	ō 188	θ 204	∞ 220	┆ 236	┆ 252
D	┆ 141	┆ 157	¼ 173	ô 189	ä 205	± 221	┆ 237	┆ 253
E	┆ 142	┆ 158	Ā 174	ü 190	á 206	÷ 222	┆ 238	┆ 254
F	┆ 143	┆ 159	ë 175	ú 191	à 207	π 223	┆ 239	┆ 255



# Star Mode

(Character table: katakana)

Hexa-decimal	8	9	A	B	C	D	E	F
0	┆ 128	┆ 144	┆ 160	┆ 176	┆ 192	┆ 208	┆ 224	┆ 240
1	┆ 129	┆ 145	。┆ 161	ア┆ 177	チ┆ 193	ム┆ 209	┆ 225	┆ 241
2	┆ 130	。┆ 146	┆ 162	イ┆ 178	ツ┆ 194	メ┆ 210	┆ 226	┆ 242
3	┆ 131	。┆ 147	┆ 163	ウ┆ 179	テ┆ 195	モ┆ 211	┆ 227	┆ 243
4	┆ 132	。┆ 148	、┆ 164	エ┆ 180	ト┆ 196	ヤ┆ 212	┆ 228	┆ 244
5	┆ 133	。┆ 149	。┆ 165	オ┆ 181	ナ┆ 197	ユ┆ 213	┆ 229	┆ 245
6	┆ 134	／┆ 150	ヲ┆ 166	カ┆ 182	ニ┆ 198	ヨ┆ 214	┆ 230	┆ 246
7	┆ 135	＼┆ 151	ア┆ 167	キ┆ 183	ヌ┆ 199	ラ┆ 215	┆ 231	┆ 247
8	┆ 136	▼┆ 152	イ┆ 168	ク┆ 184	ネ┆ 200	リ┆ 216	■┆ 232	┆ 248
9	┆ 137	▲┆ 153	ウ┆ 169	ケ┆ 185	ノ┆ 201	ル┆ 217	■┆ 233	▲┆ 249
A	┆ 138	┆ 154	エ┆ 170	コ┆ 186	ハ┆ 202	レ┆ 218	┆ 234	▲┆ 250
B	┆ 139	┆ 155	オ┆ 171	サ┆ 187	ヒ┆ 203	ロ┆ 219	┆ 235	＝┆ 251
C	┆ 140	┆ 156	ヤ┆ 172	シ┆ 188	フ┆ 204	ワ┆ 220	┆ 236	＝┆ 252
D	┆ 141	┆ 157	ユ┆ 173	ス┆ 189	ヘ┆ 205	ン┆ 221	┆ 237	┆ 253
E	┆ 142	。┆ 158	ヨ┆ 174	セ┆ 190	ホ┆ 206	。┆ 222	┆ 238	┆ 254
F	┆ 143	×┆ 159	ツ┆ 175	ソ┆ 191	マ┆ 207	。┆ 223	┆ 239	┆ 255

# Star Mode

(Character table: IBM)

Hexa- decimal	8	9	A	B	C	D	E	F
0	Ç <span style="border: 1px solid black; padding: 0 5px;">128</span>	É <span style="border: 1px solid black; padding: 0 5px;">144</span>	á <span style="border: 1px solid black; padding: 0 5px;">160</span>	<span style="border: 1px solid black; padding: 0 5px;">176</span>	L <span style="border: 1px solid black; padding: 0 5px;">192</span>	⌌ <span style="border: 1px solid black; padding: 0 5px;">208</span>	α <span style="border: 1px solid black; padding: 0 5px;">224</span>	≡ <span style="border: 1px solid black; padding: 0 5px;">240</span>
1	ü <span style="border: 1px solid black; padding: 0 5px;">129</span>	æ <span style="border: 1px solid black; padding: 0 5px;">145</span>	í <span style="border: 1px solid black; padding: 0 5px;">161</span>	<span style="border: 1px solid black; padding: 0 5px;">177</span>	⌞ <span style="border: 1px solid black; padding: 0 5px;">193</span>	⌘ <span style="border: 1px solid black; padding: 0 5px;">209</span>	β <span style="border: 1px solid black; padding: 0 5px;">225</span>	± <span style="border: 1px solid black; padding: 0 5px;">241</span>
2	é <span style="border: 1px solid black; padding: 0 5px;">130</span>	Æ <span style="border: 1px solid black; padding: 0 5px;">146</span>	ó <span style="border: 1px solid black; padding: 0 5px;">162</span>	<span style="border: 1px solid black; padding: 0 5px;">178</span>	⌟ <span style="border: 1px solid black; padding: 0 5px;">194</span>	⌡ <span style="border: 1px solid black; padding: 0 5px;">210</span>	Γ <span style="border: 1px solid black; padding: 0 5px;">226</span>	≥ <span style="border: 1px solid black; padding: 0 5px;">242</span>
3	â <span style="border: 1px solid black; padding: 0 5px;">131</span>	ô <span style="border: 1px solid black; padding: 0 5px;">147</span>	ú <span style="border: 1px solid black; padding: 0 5px;">163</span>	<span style="border: 1px solid black; padding: 0 5px;">179</span>	⌠ <span style="border: 1px solid black; padding: 0 5px;">195</span>	⌢ <span style="border: 1px solid black; padding: 0 5px;">211</span>	π <span style="border: 1px solid black; padding: 0 5px;">227</span>	≤ <span style="border: 1px solid black; padding: 0 5px;">243</span>
4	ä <span style="border: 1px solid black; padding: 0 5px;">132</span>	ö <span style="border: 1px solid black; padding: 0 5px;">148</span>	ñ <span style="border: 1px solid black; padding: 0 5px;">164</span>	⌡ <span style="border: 1px solid black; padding: 0 5px;">180</span>	- <span style="border: 1px solid black; padding: 0 5px;">196</span>	⌣ <span style="border: 1px solid black; padding: 0 5px;">212</span>	Σ <span style="border: 1px solid black; padding: 0 5px;">228</span>	∫ <span style="border: 1px solid black; padding: 0 5px;">244</span>
5	à <span style="border: 1px solid black; padding: 0 5px;">133</span>	ò <span style="border: 1px solid black; padding: 0 5px;">149</span>	Ñ <span style="border: 1px solid black; padding: 0 5px;">165</span>	⌢ <span style="border: 1px solid black; padding: 0 5px;">181</span>	⌤ <span style="border: 1px solid black; padding: 0 5px;">197</span>	⌦ <span style="border: 1px solid black; padding: 0 5px;">213</span>	σ <span style="border: 1px solid black; padding: 0 5px;">229</span>	J <span style="border: 1px solid black; padding: 0 5px;">245</span>
6	â <span style="border: 1px solid black; padding: 0 5px;">134</span>	û <span style="border: 1px solid black; padding: 0 5px;">150</span>	a <span style="border: 1px solid black; padding: 0 5px;">166</span>	⌣ <span style="border: 1px solid black; padding: 0 5px;">182</span>	⌥ <span style="border: 1px solid black; padding: 0 5px;">198</span>	⌨ <span style="border: 1px solid black; padding: 0 5px;">214</span>	μ <span style="border: 1px solid black; padding: 0 5px;">230</span>	÷ <span style="border: 1px solid black; padding: 0 5px;">246</span>
7	ç <span style="border: 1px solid black; padding: 0 5px;">135</span>	ù <span style="border: 1px solid black; padding: 0 5px;">151</span>	o <span style="border: 1px solid black; padding: 0 5px;">167</span>	⌤ <span style="border: 1px solid black; padding: 0 5px;">183</span>	⌧ <span style="border: 1px solid black; padding: 0 5px;">199</span>	〉 <span style="border: 1px solid black; padding: 0 5px;">215</span>	τ <span style="border: 1px solid black; padding: 0 5px;">231</span>	≈ <span style="border: 1px solid black; padding: 0 5px;">247</span>
8	ê <span style="border: 1px solid black; padding: 0 5px;">136</span>	ÿ <span style="border: 1px solid black; padding: 0 5px;">152</span>	¿ <span style="border: 1px solid black; padding: 0 5px;">168</span>	⌥ <span style="border: 1px solid black; padding: 0 5px;">184</span>	〈 <span style="border: 1px solid black; padding: 0 5px;">200</span>	⌫ <span style="border: 1px solid black; padding: 0 5px;">216</span>	Φ <span style="border: 1px solid black; padding: 0 5px;">232</span>	° <span style="border: 1px solid black; padding: 0 5px;">248</span>
9	ë <span style="border: 1px solid black; padding: 0 5px;">137</span>	Ö <span style="border: 1px solid black; padding: 0 5px;">153</span>	⌦ <span style="border: 1px solid black; padding: 0 5px;">169</span>	⌧ <span style="border: 1px solid black; padding: 0 5px;">185</span>	⌫ <span style="border: 1px solid black; padding: 0 5px;">201</span>	⌭ <span style="border: 1px solid black; padding: 0 5px;">217</span>	Θ <span style="border: 1px solid black; padding: 0 5px;">233</span>	· <span style="border: 1px solid black; padding: 0 5px;">249</span>
A	è <span style="border: 1px solid black; padding: 0 5px;">138</span>	Ü <span style="border: 1px solid black; padding: 0 5px;">154</span>	⌧ <span style="border: 1px solid black; padding: 0 5px;">170</span>	⌨ <span style="border: 1px solid black; padding: 0 5px;">186</span>	⌭ <span style="border: 1px solid black; padding: 0 5px;">202</span>	⌯ <span style="border: 1px solid black; padding: 0 5px;">218</span>	Ω <span style="border: 1px solid black; padding: 0 5px;">234</span>	- <span style="border: 1px solid black; padding: 0 5px;">250</span>
B	ï <span style="border: 1px solid black; padding: 0 5px;">139</span>	Ç <span style="border: 1px solid black; padding: 0 5px;">155</span>	½ <span style="border: 1px solid black; padding: 0 5px;">171</span>	⌭ <span style="border: 1px solid black; padding: 0 5px;">187</span>	⌯ <span style="border: 1px solid black; padding: 0 5px;">203</span>	■ <span style="border: 1px solid black; padding: 0 5px;">219</span>	δ <span style="border: 1px solid black; padding: 0 5px;">235</span>	√ <span style="border: 1px solid black; padding: 0 5px;">251</span>
C	î <span style="border: 1px solid black; padding: 0 5px;">140</span>	£ <span style="border: 1px solid black; padding: 0 5px;">156</span>	¼ <span style="border: 1px solid black; padding: 0 5px;">172</span>	⌯ <span style="border: 1px solid black; padding: 0 5px;">188</span>	⌰ <span style="border: 1px solid black; padding: 0 5px;">204</span>	■ <span style="border: 1px solid black; padding: 0 5px;">220</span>	∞ <span style="border: 1px solid black; padding: 0 5px;">236</span>	∩ <span style="border: 1px solid black; padding: 0 5px;">252</span>
D	ì <span style="border: 1px solid black; padding: 0 5px;">141</span>	¥ <span style="border: 1px solid black; padding: 0 5px;">157</span>	ì <span style="border: 1px solid black; padding: 0 5px;">173</span>	⌰ <span style="border: 1px solid black; padding: 0 5px;">189</span>	= <span style="border: 1px solid black; padding: 0 5px;">205</span>	⌱ <span style="border: 1px solid black; padding: 0 5px;">221</span>	φ <span style="border: 1px solid black; padding: 0 5px;">237</span>	² <span style="border: 1px solid black; padding: 0 5px;">253</span>
E	Ä <span style="border: 1px solid black; padding: 0 5px;">142</span>	Ŕ <span style="border: 1px solid black; padding: 0 5px;">158</span>	« <span style="border: 1px solid black; padding: 0 5px;">174</span>	⌱ <span style="border: 1px solid black; padding: 0 5px;">190</span>	⌲ <span style="border: 1px solid black; padding: 0 5px;">206</span>	⌳ <span style="border: 1px solid black; padding: 0 5px;">222</span>	ε <span style="border: 1px solid black; padding: 0 5px;">238</span>	▪ <span style="border: 1px solid black; padding: 0 5px;">254</span>
F	Å <span style="border: 1px solid black; padding: 0 5px;">143</span>	f <span style="border: 1px solid black; padding: 0 5px;">159</span>	» <span style="border: 1px solid black; padding: 0 5px;">175</span>	⌳ <span style="border: 1px solid black; padding: 0 5px;">191</span>	⌴ <span style="border: 1px solid black; padding: 0 5px;">207</span>	■ <span style="border: 1px solid black; padding: 0 5px;">223</span>	∪ <span style="border: 1px solid black; padding: 0 5px;">239</span>	

# Star Mode

## International Character Set

	35	36	64	91	92	93	94	96	123	124	125	126
U. S. A.	#	\$	@	[	\	]	^	`	{		}	~
France	#	\$	à	°	ç	§	^	`	é	ù	è	¨
Germany	#	\$	§	Ä	Ö	Ü	^	`	ä	ö	ü	ß
England	£	\$	@	[	\	]	^	`	{		}	~
Denmark 1	#	\$	@	Æ	Ø	Å	^	`	æ	ø	å	~
Sweden	#	¤	É	Ä	Ö	Å	Ü	é	ä	ö	å	ü
Italy	#	\$	@	°	\	é	^	ù	à	ò	è	ì
Spain 1	Rs	\$	@	ı	Ñ	¿	^	'	¨	ñ	}	~
Japan	#	\$	@	[	¥	]	^	`	{		}	~
Norway	#	¤	É	Æ	Ø	Å	Ü	é	æ	ø	å	ü
Denmark 2	#	\$	É	Æ	Ø	Å	Ü	é	æ	ø	å	ü
Spain 2	#	\$	á	ı	Ñ	¿	é	'	ı	ñ	ó	ú
Latin America	#	\$	á	ı	Ñ	¿	é	ü	ı	ñ	ó	ú

# ESC/POS Mode

Hexa- decimal	0	1	2	3	4	5	6	7
0	<NUL> 0	<DLE> 16	SP 32	0 48	@ 64	P 80	` 96	p 112
1	1	<XON> 17	! 33	1 49	A 65	Q 81	a 97	q 113
2	2	18	" 34	2 50	B 66	R 82	b 98	r 114
3	3	<XOFF> 19	# 35	3 51	C 67	S 83	c 99	s 115
4	<EOT> 4	20	\$ 36	4 52	D 68	T 84	d 100	t 116
5	<ENQ> 5	21	% 37	5 53	E 69	U 85	e 101	u 117
6	6	22	& 38	6 54	F 70	V 86	f 102	v 118
7	7	23	' 39	7 55	G 71	W 87	g 103	w 119
8	8	<CAN> 24	( 40	8 56	H 72	X 88	h 104	x 120
9	<HT> 9	25	) 41	9 57	I 73	Y 89	i 105	y 121
A	<LF> 10	26	* 42	: 58	J 74	Z 90	j 106	z 122
B	11	<ESC> 27	+ 43	; 59	K 75	[ 91	k 107	{ 123
C	<FF> 12	28	, 44	< 60	L 76	\ 92	l 108	 124
D	13	<GS> 29	- 45	= 61	M 77	] 93	m 109	} 125
E	14	30	. 46	> 62	N 78	^ 94	n 110	~ 126
F	15	31	/ 47	? 63	O 79	_ 95	o 111	SP 127

# ESC/POS Mode

Page 0 (PC437: USA, Standard Europe)

Hexa- decimal	8	9	A	B	C	D	E	F
0	Ç <span style="border: 1px solid black; padding: 0 2px;">128</span>	É <span style="border: 1px solid black; padding: 0 2px;">144</span>	á <span style="border: 1px solid black; padding: 0 2px;">160</span>	<span style="border: 1px solid black; padding: 0 2px;">176</span>	Ł <span style="border: 1px solid black; padding: 0 2px;">192</span>	⋈ <span style="border: 1px solid black; padding: 0 2px;">208</span>	α <span style="border: 1px solid black; padding: 0 2px;">224</span>	≡ <span style="border: 1px solid black; padding: 0 2px;">240</span>
1	ü <span style="border: 1px solid black; padding: 0 2px;">129</span>	æ <span style="border: 1px solid black; padding: 0 2px;">145</span>	í <span style="border: 1px solid black; padding: 0 2px;">161</span>	<span style="border: 1px solid black; padding: 0 2px;">177</span>	⊥ <span style="border: 1px solid black; padding: 0 2px;">193</span>	⌘ <span style="border: 1px solid black; padding: 0 2px;">209</span>	β <span style="border: 1px solid black; padding: 0 2px;">225</span>	± <span style="border: 1px solid black; padding: 0 2px;">241</span>
2	é <span style="border: 1px solid black; padding: 0 2px;">130</span>	Æ <span style="border: 1px solid black; padding: 0 2px;">146</span>	ó <span style="border: 1px solid black; padding: 0 2px;">162</span>	<span style="border: 1px solid black; padding: 0 2px;">178</span>	⌘ <span style="border: 1px solid black; padding: 0 2px;">194</span>	π <span style="border: 1px solid black; padding: 0 2px;">210</span>	Γ <span style="border: 1px solid black; padding: 0 2px;">226</span>	≥ <span style="border: 1px solid black; padding: 0 2px;">242</span>
3	â <span style="border: 1px solid black; padding: 0 2px;">131</span>	ô <span style="border: 1px solid black; padding: 0 2px;">147</span>	ú <span style="border: 1px solid black; padding: 0 2px;">163</span>	<span style="border: 1px solid black; padding: 0 2px;">179</span>	⌘ <span style="border: 1px solid black; padding: 0 2px;">195</span>	⋈ <span style="border: 1px solid black; padding: 0 2px;">211</span>	π <span style="border: 1px solid black; padding: 0 2px;">227</span>	≤ <span style="border: 1px solid black; padding: 0 2px;">243</span>
4	ä <span style="border: 1px solid black; padding: 0 2px;">132</span>	ö <span style="border: 1px solid black; padding: 0 2px;">148</span>	ñ <span style="border: 1px solid black; padding: 0 2px;">164</span>	<span style="border: 1px solid black; padding: 0 2px;">180</span>	- <span style="border: 1px solid black; padding: 0 2px;">196</span>	⌘ <span style="border: 1px solid black; padding: 0 2px;">212</span>	Σ <span style="border: 1px solid black; padding: 0 2px;">228</span>	∫ <span style="border: 1px solid black; padding: 0 2px;">244</span>
5	à <span style="border: 1px solid black; padding: 0 2px;">133</span>	ò <span style="border: 1px solid black; padding: 0 2px;">149</span>	Ñ <span style="border: 1px solid black; padding: 0 2px;">165</span>	<span style="border: 1px solid black; padding: 0 2px;">181</span>	⌘ <span style="border: 1px solid black; padding: 0 2px;">197</span>	⌘ <span style="border: 1px solid black; padding: 0 2px;">213</span>	σ <span style="border: 1px solid black; padding: 0 2px;">229</span>	⋈ <span style="border: 1px solid black; padding: 0 2px;">245</span>
6	â <span style="border: 1px solid black; padding: 0 2px;">134</span>	û <span style="border: 1px solid black; padding: 0 2px;">150</span>	a <span style="border: 1px solid black; padding: 0 2px;">166</span>	<span style="border: 1px solid black; padding: 0 2px;">182</span>	⌘ <span style="border: 1px solid black; padding: 0 2px;">198</span>	π <span style="border: 1px solid black; padding: 0 2px;">214</span>	μ <span style="border: 1px solid black; padding: 0 2px;">230</span>	÷ <span style="border: 1px solid black; padding: 0 2px;">246</span>
7	ç <span style="border: 1px solid black; padding: 0 2px;">135</span>	ù <span style="border: 1px solid black; padding: 0 2px;">151</span>	o <span style="border: 1px solid black; padding: 0 2px;">167</span>	π <span style="border: 1px solid black; padding: 0 2px;">183</span>	<span style="border: 1px solid black; padding: 0 2px;">199</span>	⌘ <span style="border: 1px solid black; padding: 0 2px;">215</span>	τ <span style="border: 1px solid black; padding: 0 2px;">231</span>	≈ <span style="border: 1px solid black; padding: 0 2px;">247</span>
8	ê <span style="border: 1px solid black; padding: 0 2px;">136</span>	ÿ <span style="border: 1px solid black; padding: 0 2px;">152</span>	¿ <span style="border: 1px solid black; padding: 0 2px;">168</span>	ƒ <span style="border: 1px solid black; padding: 0 2px;">184</span>	⌘ <span style="border: 1px solid black; padding: 0 2px;">200</span>	⌘ <span style="border: 1px solid black; padding: 0 2px;">216</span>	Φ <span style="border: 1px solid black; padding: 0 2px;">232</span>	° <span style="border: 1px solid black; padding: 0 2px;">248</span>
9	ë <span style="border: 1px solid black; padding: 0 2px;">137</span>	Ö <span style="border: 1px solid black; padding: 0 2px;">153</span>	ƒ <span style="border: 1px solid black; padding: 0 2px;">169</span>	<span style="border: 1px solid black; padding: 0 2px;">185</span>	⌘ <span style="border: 1px solid black; padding: 0 2px;">201</span>	⌘ <span style="border: 1px solid black; padding: 0 2px;">217</span>	Θ <span style="border: 1px solid black; padding: 0 2px;">233</span>	• <span style="border: 1px solid black; padding: 0 2px;">249</span>
A	è <span style="border: 1px solid black; padding: 0 2px;">138</span>	Ü <span style="border: 1px solid black; padding: 0 2px;">154</span>	ƒ <span style="border: 1px solid black; padding: 0 2px;">170</span>	<span style="border: 1px solid black; padding: 0 2px;">186</span>	⋈ <span style="border: 1px solid black; padding: 0 2px;">202</span>	ƒ <span style="border: 1px solid black; padding: 0 2px;">218</span>	Ω <span style="border: 1px solid black; padding: 0 2px;">234</span>	· <span style="border: 1px solid black; padding: 0 2px;">250</span>
B	ï <span style="border: 1px solid black; padding: 0 2px;">139</span>	Ç <span style="border: 1px solid black; padding: 0 2px;">155</span>	½ <span style="border: 1px solid black; padding: 0 2px;">171</span>	⌘ <span style="border: 1px solid black; padding: 0 2px;">187</span>	⌘ <span style="border: 1px solid black; padding: 0 2px;">203</span>	■ <span style="border: 1px solid black; padding: 0 2px;">219</span>	δ <span style="border: 1px solid black; padding: 0 2px;">235</span>	√ <span style="border: 1px solid black; padding: 0 2px;">251</span>
C	î <span style="border: 1px solid black; padding: 0 2px;">140</span>	£ <span style="border: 1px solid black; padding: 0 2px;">156</span>	¼ <span style="border: 1px solid black; padding: 0 2px;">172</span>	⌘ <span style="border: 1px solid black; padding: 0 2px;">188</span>	<span style="border: 1px solid black; padding: 0 2px;">204</span>	■ <span style="border: 1px solid black; padding: 0 2px;">220</span>	∞ <span style="border: 1px solid black; padding: 0 2px;">236</span>	ⁿ <span style="border: 1px solid black; padding: 0 2px;">252</span>
D	ì <span style="border: 1px solid black; padding: 0 2px;">141</span>	¥ <span style="border: 1px solid black; padding: 0 2px;">157</span>	ì <span style="border: 1px solid black; padding: 0 2px;">173</span>	⋈ <span style="border: 1px solid black; padding: 0 2px;">189</span>	= <span style="border: 1px solid black; padding: 0 2px;">205</span>	<span style="border: 1px solid black; padding: 0 2px;">221</span>	φ <span style="border: 1px solid black; padding: 0 2px;">237</span>	² <span style="border: 1px solid black; padding: 0 2px;">253</span>
E	Ä <span style="border: 1px solid black; padding: 0 2px;">142</span>	ƒ <span style="border: 1px solid black; padding: 0 2px;">158</span>	« <span style="border: 1px solid black; padding: 0 2px;">174</span>	⌘ <span style="border: 1px solid black; padding: 0 2px;">190</span>	⌘ <span style="border: 1px solid black; padding: 0 2px;">206</span>	<span style="border: 1px solid black; padding: 0 2px;">222</span>	€ <span style="border: 1px solid black; padding: 0 2px;">238</span>	▪ <span style="border: 1px solid black; padding: 0 2px;">254</span>
F	Å <span style="border: 1px solid black; padding: 0 2px;">143</span>	f <span style="border: 1px solid black; padding: 0 2px;">159</span>	» <span style="border: 1px solid black; padding: 0 2px;">175</span>	⌘ <span style="border: 1px solid black; padding: 0 2px;">191</span>	⋈ <span style="border: 1px solid black; padding: 0 2px;">207</span>	■ <span style="border: 1px solid black; padding: 0 2px;">223</span>	∩ <span style="border: 1px solid black; padding: 0 2px;">239</span>	SP <span style="border: 1px solid black; padding: 0 2px;">255</span>

# ESC/POS Mode

## Page 1(Katakana)

Hexa- decimal	8	9	A	B	C	D	E	F
0	— 128	⊥ 144	SP 160	— 176	タ 192	ミ 208	= 224	× 240
1	— 129	⊥ 145	。○ 161	ア 177	チ 193	ム 209	⊥ 225	円 241
2	— 130	⊥ 146	「 162	イ 178	ツ 194	メ 210	⊥ 226	年 242
3	— 131	⊥ 147	」 163	ウ 179	テ 195	モ 211	⊥ 227	月 243
4	■ 132	— 148	、 164	エ 180	ト 196	ヤ 212	▲ 228	日 244
5	■ 133	— 149	・ 165	オ 181	ナ 197	ユ 213	▲ 229	時 245
6	■ 134	丨 150	ヲ 166	カ 182	ニ 198	ヨ 214	▼ 230	分 246
7	■ 135	丨 151	ア 167	キ 183	ヌ 199	ラ 215	▼ 231	秒 247
8	丨 136	┌ 152	イ 168	ク 184	ネ 200	リ 216	♠ 232	〒 248
9	丨 137	┐ 153	ウ 169	ケ 185	ノ 201	ル 217	♥ 233	市 249
A	丨 138	└ 154	エ 170	コ 186	ハ 202	レ 218	◆ 234	区 250
B	■ 139	┌ 155	オ 171	サ 187	ヒ 203	ロ 219	♣ 235	町 251
C	■ 140	┐ 156	ヤ 172	シ 188	フ 204	ワ 220	● 236	村 252
D	■ 141	└ 157	ユ 173	ス 189	ヘ 205	ン 221	○ 237	人 253
E	■ 142	┌ 158	ヨ 174	セ 190	ホ 206	、 222	/ 238	※ 254
F	+ 143	┐ 159	ツ 175	ソ 191	マ 207	。 223	＼ 239	SP 255

# ESC/POS Mode

Page 2 (PC850: Multilingual)

Hexa-decimal	8	9	A	B	C	D	E	F
0	Ç <span style="float:right">128</span>	É <span style="float:right">144</span>	á <span style="float:right">160</span>	⋮ <span style="float:right">176</span>	Ł <span style="float:right">192</span>	ǰ <span style="float:right">208</span>	α <span style="float:right">224</span>	— <span style="float:right">240</span>
1	ü <span style="float:right">129</span>	æ <span style="float:right">145</span>	í <span style="float:right">161</span>	⋮ <span style="float:right">177</span>	Ł̄ <span style="float:right">193</span>	Đ <span style="float:right">209</span>	β <span style="float:right">225</span>	± <span style="float:right">241</span>
2	é <span style="float:right">130</span>	Æ <span style="float:right">146</span>	ó <span style="float:right">162</span>	⋮ <span style="float:right">178</span>	Ŧ <span style="float:right">194</span>	Ê <span style="float:right">210</span>	Ô <span style="float:right">226</span>	= <span style="float:right">242</span>
3	â <span style="float:right">131</span>	ô <span style="float:right">147</span>	ú <span style="float:right">163</span>	<span style="float:right">179</span>	Ŧ̄ <span style="float:right">195</span>	Ë <span style="float:right">211</span>	Ò <span style="float:right">227</span>	<sup>3</sup> / <sub>4</sub> <span style="float:right">243</span>
4	ä <span style="float:right">132</span>	ö <span style="float:right">148</span>	ñ <span style="float:right">164</span>	̄ <span style="float:right">180</span>	- <span style="float:right">196</span>	È <span style="float:right">212</span>	õ <span style="float:right">228</span>	¶ <span style="float:right">244</span>
5	à <span style="float:right">133</span>	ò <span style="float:right">149</span>	Ñ <span style="float:right">165</span>	Á <span style="float:right">181</span>	+ <span style="float:right">197</span>	ŧ <span style="float:right">213</span>	Õ <span style="float:right">229</span>	§ <span style="float:right">245</span>
6	á <span style="float:right">134</span>	û <span style="float:right">150</span>	à <span style="float:right">166</span>	Â <span style="float:right">182</span>	ã <span style="float:right">198</span>	Í <span style="float:right">214</span>	μ <span style="float:right">230</span>	÷ <span style="float:right">246</span>
7	ç <span style="float:right">135</span>	ù <span style="float:right">151</span>	ó <span style="float:right">167</span>	À <span style="float:right">183</span>	Ã <span style="float:right">199</span>	Î <span style="float:right">215</span>	Đ̄ <span style="float:right">231</span>	┘ <span style="float:right">247</span>
8	ê <span style="float:right">136</span>	ÿ <span style="float:right">152</span>	ı <span style="float:right">168</span>	© <span style="float:right">184</span>	Ł̄̄ <span style="float:right">200</span>	Ï <span style="float:right">216</span>	Đ̄̄ <span style="float:right">232</span>	° <span style="float:right">248</span>
9	ë <span style="float:right">137</span>	Ö <span style="float:right">153</span>	® <span style="float:right">169</span>	¶̄ <span style="float:right">185</span>	Ŧ̄̄ <span style="float:right">201</span>	Ј <span style="float:right">217</span>	Ú <span style="float:right">233</span>	” <span style="float:right">249</span>
A	è <span style="float:right">138</span>	Ü <span style="float:right">154</span>	¬ <span style="float:right">170</span>	¶̄̄ <span style="float:right">186</span>	Ŧ̄̄̄ <span style="float:right">202</span>	Ŧ̄̄̄ <span style="float:right">218</span>	Û <span style="float:right">234</span>	• <span style="float:right">250</span>
B	ï <span style="float:right">139</span>	ø <span style="float:right">155</span>	<sup>1</sup> / <sub>2</sub> <span style="float:right">171</span>	¶̄̄̄ <span style="float:right">187</span>	Ŧ̄̄̄̄ <span style="float:right">203</span>	■ <span style="float:right">219</span>	Û̄ <span style="float:right">235</span>	<sup>1</sup> <span style="float:right">251</span>
C	î <span style="float:right">140</span>	£ <span style="float:right">156</span>	<sup>1</sup> / <sub>4</sub> <span style="float:right">172</span>	¶̄̄̄̄ <span style="float:right">188</span>	Ŧ̄̄̄̄̄ <span style="float:right">204</span>	■̄ <span style="float:right">220</span>	Ý <span style="float:right">236</span>	<sup>3</sup> <span style="float:right">252</span>
D	ì <span style="float:right">141</span>	Ø <span style="float:right">157</span>	ı̄ <span style="float:right">173</span>	Ç̄ <span style="float:right">189</span>	= <span style="float:right">205</span>	ı̄̄ <span style="float:right">221</span>	Ý̄ <span style="float:right">237</span>	<sup>2</sup> <span style="float:right">253</span>
E	Ä <span style="float:right">142</span>	× <span style="float:right">158</span>	« <span style="float:right">174</span>	¥ <span style="float:right">190</span>	¶̄̄̄̄̄ <span style="float:right">206</span>	İ̄ <span style="float:right">222</span>	—̄ <span style="float:right">238</span>	▪ <span style="float:right">254</span>
F	Å <span style="float:right">143</span>	f <span style="float:right">159</span>	» <span style="float:right">175</span>	Ŧ̄̄̄̄̄ <span style="float:right">191</span>	Ω <span style="float:right">207</span>	■̄̄ <span style="float:right">223</span>	’ <span style="float:right">239</span>	SP <span style="float:right">255</span>

# ESC/POS Mode

Page 3 (PC860: Portuguese)

Hexa- decimal	8	9	A	B	C	D	E	F
0	Ç <span style="border: 1px solid black; padding: 0 2px;">128</span>	É <span style="border: 1px solid black; padding: 0 2px;">144</span>	á <span style="border: 1px solid black; padding: 0 2px;">160</span>	<span style="border: 1px solid black; padding: 0 2px;">176</span>	L <span style="border: 1px solid black; padding: 0 2px;">192</span>	⏏ <span style="border: 1px solid black; padding: 0 2px;">208</span>	α <span style="border: 1px solid black; padding: 0 2px;">224</span>	≡ <span style="border: 1px solid black; padding: 0 2px;">240</span>
1	ü <span style="border: 1px solid black; padding: 0 2px;">129</span>	À <span style="border: 1px solid black; padding: 0 2px;">145</span>	í <span style="border: 1px solid black; padding: 0 2px;">161</span>	<span style="border: 1px solid black; padding: 0 2px;">177</span>	⌞ <span style="border: 1px solid black; padding: 0 2px;">193</span>	⏏ <span style="border: 1px solid black; padding: 0 2px;">209</span>	β <span style="border: 1px solid black; padding: 0 2px;">225</span>	± <span style="border: 1px solid black; padding: 0 2px;">241</span>
2	é <span style="border: 1px solid black; padding: 0 2px;">130</span>	È <span style="border: 1px solid black; padding: 0 2px;">146</span>	ó <span style="border: 1px solid black; padding: 0 2px;">162</span>	<span style="border: 1px solid black; padding: 0 2px;">178</span>	T <span style="border: 1px solid black; padding: 0 2px;">194</span>	π <span style="border: 1px solid black; padding: 0 2px;">210</span>	Γ <span style="border: 1px solid black; padding: 0 2px;">226</span>	≥ <span style="border: 1px solid black; padding: 0 2px;">242</span>
3	â <span style="border: 1px solid black; padding: 0 2px;">131</span>	ô <span style="border: 1px solid black; padding: 0 2px;">147</span>	ú <span style="border: 1px solid black; padding: 0 2px;">163</span>	<span style="border: 1px solid black; padding: 0 2px;">179</span>	⌞ <span style="border: 1px solid black; padding: 0 2px;">195</span>	⏏ <span style="border: 1px solid black; padding: 0 2px;">211</span>	π <span style="border: 1px solid black; padding: 0 2px;">227</span>	≤ <span style="border: 1px solid black; padding: 0 2px;">243</span>
4	ã <span style="border: 1px solid black; padding: 0 2px;">132</span>	õ <span style="border: 1px solid black; padding: 0 2px;">148</span>	ñ <span style="border: 1px solid black; padding: 0 2px;">164</span>	<span style="border: 1px solid black; padding: 0 2px;">180</span>	- <span style="border: 1px solid black; padding: 0 2px;">196</span>	⏏ <span style="border: 1px solid black; padding: 0 2px;">212</span>	Σ <span style="border: 1px solid black; padding: 0 2px;">228</span>	∫ <span style="border: 1px solid black; padding: 0 2px;">244</span>
5	à <span style="border: 1px solid black; padding: 0 2px;">133</span>	ò <span style="border: 1px solid black; padding: 0 2px;">149</span>	Ñ <span style="border: 1px solid black; padding: 0 2px;">165</span>	<span style="border: 1px solid black; padding: 0 2px;">181</span>	⌞ <span style="border: 1px solid black; padding: 0 2px;">197</span>	F <span style="border: 1px solid black; padding: 0 2px;">213</span>	σ <span style="border: 1px solid black; padding: 0 2px;">229</span>	J <span style="border: 1px solid black; padding: 0 2px;">245</span>
6	Á <span style="border: 1px solid black; padding: 0 2px;">134</span>	Ú <span style="border: 1px solid black; padding: 0 2px;">150</span>	a <span style="border: 1px solid black; padding: 0 2px;">166</span>	<span style="border: 1px solid black; padding: 0 2px;">182</span>	⌞ <span style="border: 1px solid black; padding: 0 2px;">198</span>	π <span style="border: 1px solid black; padding: 0 2px;">214</span>	μ <span style="border: 1px solid black; padding: 0 2px;">230</span>	÷ <span style="border: 1px solid black; padding: 0 2px;">246</span>
7	ç <span style="border: 1px solid black; padding: 0 2px;">135</span>	ù <span style="border: 1px solid black; padding: 0 2px;">151</span>	o <span style="border: 1px solid black; padding: 0 2px;">167</span>	π <span style="border: 1px solid black; padding: 0 2px;">183</span>	<span style="border: 1px solid black; padding: 0 2px;">199</span>	<span style="border: 1px solid black; padding: 0 2px;">215</span>	τ <span style="border: 1px solid black; padding: 0 2px;">231</span>	≈ <span style="border: 1px solid black; padding: 0 2px;">247</span>
8	ê <span style="border: 1px solid black; padding: 0 2px;">136</span>	Ì <span style="border: 1px solid black; padding: 0 2px;">152</span>	ç <span style="border: 1px solid black; padding: 0 2px;">168</span>	ƒ <span style="border: 1px solid black; padding: 0 2px;">184</span>	⏏ <span style="border: 1px solid black; padding: 0 2px;">200</span>	⌞ <span style="border: 1px solid black; padding: 0 2px;">216</span>	Φ <span style="border: 1px solid black; padding: 0 2px;">232</span>	° <span style="border: 1px solid black; padding: 0 2px;">248</span>
9	Ê <span style="border: 1px solid black; padding: 0 2px;">137</span>	Õ <span style="border: 1px solid black; padding: 0 2px;">153</span>	Ò <span style="border: 1px solid black; padding: 0 2px;">169</span>	<span style="border: 1px solid black; padding: 0 2px;">185</span>	⌞ <span style="border: 1px solid black; padding: 0 2px;">201</span>	⌞ <span style="border: 1px solid black; padding: 0 2px;">217</span>	Θ <span style="border: 1px solid black; padding: 0 2px;">233</span>	• <span style="border: 1px solid black; padding: 0 2px;">249</span>
A	è <span style="border: 1px solid black; padding: 0 2px;">138</span>	Ü <span style="border: 1px solid black; padding: 0 2px;">154</span>	¬ <span style="border: 1px solid black; padding: 0 2px;">170</span>	<span style="border: 1px solid black; padding: 0 2px;">186</span>	⏏ <span style="border: 1px solid black; padding: 0 2px;">202</span>	⌞ <span style="border: 1px solid black; padding: 0 2px;">218</span>	Ω <span style="border: 1px solid black; padding: 0 2px;">234</span>	· <span style="border: 1px solid black; padding: 0 2px;">250</span>
B	Í <span style="border: 1px solid black; padding: 0 2px;">139</span>	Ç <span style="border: 1px solid black; padding: 0 2px;">155</span>	½ <span style="border: 1px solid black; padding: 0 2px;">171</span>	⌞ <span style="border: 1px solid black; padding: 0 2px;">187</span>	⌞ <span style="border: 1px solid black; padding: 0 2px;">203</span>	■ <span style="border: 1px solid black; padding: 0 2px;">219</span>	δ <span style="border: 1px solid black; padding: 0 2px;">235</span>	√ <span style="border: 1px solid black; padding: 0 2px;">251</span>
C	Ô <span style="border: 1px solid black; padding: 0 2px;">140</span>	£ <span style="border: 1px solid black; padding: 0 2px;">156</span>	¼ <span style="border: 1px solid black; padding: 0 2px;">172</span>	⌞ <span style="border: 1px solid black; padding: 0 2px;">188</span>	<span style="border: 1px solid black; padding: 0 2px;">204</span>	■ <span style="border: 1px solid black; padding: 0 2px;">220</span>	∞ <span style="border: 1px solid black; padding: 0 2px;">236</span>	n <span style="border: 1px solid black; padding: 0 2px;">252</span>
D	ì <span style="border: 1px solid black; padding: 0 2px;">141</span>	Ù <span style="border: 1px solid black; padding: 0 2px;">157</span>	ì <span style="border: 1px solid black; padding: 0 2px;">173</span>	⏏ <span style="border: 1px solid black; padding: 0 2px;">189</span>	= <span style="border: 1px solid black; padding: 0 2px;">205</span>	<span style="border: 1px solid black; padding: 0 2px;">221</span>	φ <span style="border: 1px solid black; padding: 0 2px;">237</span>	² <span style="border: 1px solid black; padding: 0 2px;">253</span>
E	Ã <span style="border: 1px solid black; padding: 0 2px;">142</span>	⌞ <span style="border: 1px solid black; padding: 0 2px;">158</span>	« <span style="border: 1px solid black; padding: 0 2px;">174</span>	⌞ <span style="border: 1px solid black; padding: 0 2px;">190</span>	<span style="border: 1px solid black; padding: 0 2px;">206</span>	<span style="border: 1px solid black; padding: 0 2px;">222</span>	€ <span style="border: 1px solid black; padding: 0 2px;">238</span>	▪ <span style="border: 1px solid black; padding: 0 2px;">254</span>
F	Â <span style="border: 1px solid black; padding: 0 2px;">143</span>	Ó <span style="border: 1px solid black; padding: 0 2px;">159</span>	» <span style="border: 1px solid black; padding: 0 2px;">175</span>	⌞ <span style="border: 1px solid black; padding: 0 2px;">191</span>	⏏ <span style="border: 1px solid black; padding: 0 2px;">207</span>	■ <span style="border: 1px solid black; padding: 0 2px;">223</span>	∩ <span style="border: 1px solid black; padding: 0 2px;">239</span>	SP <span style="border: 1px solid black; padding: 0 2px;">255</span>





# ESC/POS Mode

Page 4 (PC863: Canadian-French)

Hexa- decimal	8	9	A	B	C	D	E	F
0	Ç <span style="border: 1px solid black; padding: 2px;">128</span>	É <span style="border: 1px solid black; padding: 2px;">144</span>	Ì <span style="border: 1px solid black; padding: 2px;">160</span>	⋮ <span style="border: 1px solid black; padding: 2px;">176</span>	Ł <span style="border: 1px solid black; padding: 2px;">192</span>	⋈ <span style="border: 1px solid black; padding: 2px;">208</span>	α <span style="border: 1px solid black; padding: 2px;">224</span>	≡ <span style="border: 1px solid black; padding: 2px;">240</span>
1	ü <span style="border: 1px solid black; padding: 2px;">129</span>	È <span style="border: 1px solid black; padding: 2px;">145</span>	Í <span style="border: 1px solid black; padding: 2px;">161</span>	⋱ <span style="border: 1px solid black; padding: 2px;">177</span>	⊥ <span style="border: 1px solid black; padding: 2px;">193</span>	⌒ <span style="border: 1px solid black; padding: 2px;">209</span>	β <span style="border: 1px solid black; padding: 2px;">225</span>	± <span style="border: 1px solid black; padding: 2px;">241</span>
2	é <span style="border: 1px solid black; padding: 2px;">130</span>	Ê <span style="border: 1px solid black; padding: 2px;">146</span>	Ó <span style="border: 1px solid black; padding: 2px;">162</span>	⋲ <span style="border: 1px solid black; padding: 2px;">178</span>	⌢ <span style="border: 1px solid black; padding: 2px;">194</span>	π <span style="border: 1px solid black; padding: 2px;">210</span>	Γ <span style="border: 1px solid black; padding: 2px;">226</span>	≥ <span style="border: 1px solid black; padding: 2px;">242</span>
3	â <span style="border: 1px solid black; padding: 2px;">131</span>	ô <span style="border: 1px solid black; padding: 2px;">147</span>	ú <span style="border: 1px solid black; padding: 2px;">163</span>	⌣ <span style="border: 1px solid black; padding: 2px;">179</span>	⌣ <span style="border: 1px solid black; padding: 2px;">195</span>	⋈ <span style="border: 1px solid black; padding: 2px;">211</span>	π <span style="border: 1px solid black; padding: 2px;">227</span>	≤ <span style="border: 1px solid black; padding: 2px;">243</span>
4	Â <span style="border: 1px solid black; padding: 2px;">132</span>	Ë <span style="border: 1px solid black; padding: 2px;">148</span>	Ï <span style="border: 1px solid black; padding: 2px;">164</span>	⌤ <span style="border: 1px solid black; padding: 2px;">180</span>	− <span style="border: 1px solid black; padding: 2px;">196</span>	ƒ <span style="border: 1px solid black; padding: 2px;">212</span>	Σ <span style="border: 1px solid black; padding: 2px;">228</span>	∫ <span style="border: 1px solid black; padding: 2px;">244</span>
5	à <span style="border: 1px solid black; padding: 2px;">133</span>	Ï <span style="border: 1px solid black; padding: 2px;">149</span>	Ï <span style="border: 1px solid black; padding: 2px;">165</span>	⌥ <span style="border: 1px solid black; padding: 2px;">181</span>	⌥ <span style="border: 1px solid black; padding: 2px;">197</span>	ƒ <span style="border: 1px solid black; padding: 2px;">213</span>	σ <span style="border: 1px solid black; padding: 2px;">229</span>	∫ <span style="border: 1px solid black; padding: 2px;">245</span>
6	ŕ <span style="border: 1px solid black; padding: 2px;">134</span>	û <span style="border: 1px solid black; padding: 2px;">150</span>	³ <span style="border: 1px solid black; padding: 2px;">166</span>	⌦ <span style="border: 1px solid black; padding: 2px;">182</span>	ƒ <span style="border: 1px solid black; padding: 2px;">198</span>	π <span style="border: 1px solid black; padding: 2px;">214</span>	μ <span style="border: 1px solid black; padding: 2px;">230</span>	÷ <span style="border: 1px solid black; padding: 2px;">246</span>
7	ç <span style="border: 1px solid black; padding: 2px;">135</span>	ù <span style="border: 1px solid black; padding: 2px;">151</span>	− <span style="border: 1px solid black; padding: 2px;">167</span>	π <span style="border: 1px solid black; padding: 2px;">183</span>	⌦ <span style="border: 1px solid black; padding: 2px;">199</span>	⌦ <span style="border: 1px solid black; padding: 2px;">215</span>	τ <span style="border: 1px solid black; padding: 2px;">231</span>	≈ <span style="border: 1px solid black; padding: 2px;">247</span>
8	ê <span style="border: 1px solid black; padding: 2px;">136</span>	α <span style="border: 1px solid black; padding: 2px;">152</span>	Î <span style="border: 1px solid black; padding: 2px;">168</span>	ƒ <span style="border: 1px solid black; padding: 2px;">184</span>	⌧ <span style="border: 1px solid black; padding: 2px;">200</span>	⌧ <span style="border: 1px solid black; padding: 2px;">216</span>	Φ <span style="border: 1px solid black; padding: 2px;">232</span>	° <span style="border: 1px solid black; padding: 2px;">248</span>
9	ë <span style="border: 1px solid black; padding: 2px;">137</span>	Ô <span style="border: 1px solid black; padding: 2px;">153</span>	ƒ <span style="border: 1px solid black; padding: 2px;">169</span>	⌨ <span style="border: 1px solid black; padding: 2px;">185</span>	ƒ <span style="border: 1px solid black; padding: 2px;">201</span>	ƒ <span style="border: 1px solid black; padding: 2px;">217</span>	Θ <span style="border: 1px solid black; padding: 2px;">233</span>	• <span style="border: 1px solid black; padding: 2px;">249</span>
A	è <span style="border: 1px solid black; padding: 2px;">138</span>	Û <span style="border: 1px solid black; padding: 2px;">154</span>	ƒ <span style="border: 1px solid black; padding: 2px;">170</span>	〈 <span style="border: 1px solid black; padding: 2px;">186</span>	⌧ <span style="border: 1px solid black; padding: 2px;">202</span>	ƒ <span style="border: 1px solid black; padding: 2px;">218</span>	Ω <span style="border: 1px solid black; padding: 2px;">234</span>	· <span style="border: 1px solid black; padding: 2px;">250</span>
B	ï <span style="border: 1px solid black; padding: 2px;">139</span>	Ç <span style="border: 1px solid black; padding: 2px;">155</span>	½ <span style="border: 1px solid black; padding: 2px;">171</span>	ƒ <span style="border: 1px solid black; padding: 2px;">187</span>	⌒ <span style="border: 1px solid black; padding: 2px;">203</span>	■ <span style="border: 1px solid black; padding: 2px;">219</span>	δ <span style="border: 1px solid black; padding: 2px;">235</span>	√ <span style="border: 1px solid black; padding: 2px;">251</span>
C	î <span style="border: 1px solid black; padding: 2px;">140</span>	£ <span style="border: 1px solid black; padding: 2px;">156</span>	¼ <span style="border: 1px solid black; padding: 2px;">172</span>	ƒ <span style="border: 1px solid black; padding: 2px;">188</span>	⌦ <span style="border: 1px solid black; padding: 2px;">204</span>	■ <span style="border: 1px solid black; padding: 2px;">220</span>	∞ <span style="border: 1px solid black; padding: 2px;">236</span>	ⁿ <span style="border: 1px solid black; padding: 2px;">252</span>
D	= <span style="border: 1px solid black; padding: 2px;">141</span>	Ù <span style="border: 1px solid black; padding: 2px;">157</span>	¾ <span style="border: 1px solid black; padding: 2px;">173</span>	⌧ <span style="border: 1px solid black; padding: 2px;">189</span>	= <span style="border: 1px solid black; padding: 2px;">205</span>	⌣ <span style="border: 1px solid black; padding: 2px;">221</span>	φ <span style="border: 1px solid black; padding: 2px;">237</span>	² <span style="border: 1px solid black; padding: 2px;">253</span>
E	À <span style="border: 1px solid black; padding: 2px;">142</span>	Û <span style="border: 1px solid black; padding: 2px;">158</span>	« <span style="border: 1px solid black; padding: 2px;">174</span>	ƒ <span style="border: 1px solid black; padding: 2px;">190</span>	⌦ <span style="border: 1px solid black; padding: 2px;">206</span>	⌣ <span style="border: 1px solid black; padding: 2px;">222</span>	ε <span style="border: 1px solid black; padding: 2px;">238</span>	· <span style="border: 1px solid black; padding: 2px;">254</span>
F	§ <span style="border: 1px solid black; padding: 2px;">143</span>	f <span style="border: 1px solid black; padding: 2px;">159</span>	» <span style="border: 1px solid black; padding: 2px;">175</span>	ƒ <span style="border: 1px solid black; padding: 2px;">191</span>	⌧ <span style="border: 1px solid black; padding: 2px;">207</span>	■ <span style="border: 1px solid black; padding: 2px;">223</span>	∩ <span style="border: 1px solid black; padding: 2px;">239</span>	SP <span style="border: 1px solid black; padding: 2px;">255</span>

# ESC/POS Mode

Page 5 (PC865: Nordic)

Hexa- decimal	8	9	A	B	C	D	E	F
0	Ç <span style="border: 1px solid black; padding: 0 2px;">128</span>	É <span style="border: 1px solid black; padding: 0 2px;">144</span>	á <span style="border: 1px solid black; padding: 0 2px;">160</span>	 <span style="border: 1px solid black; padding: 0 2px;">176</span>	Ł <span style="border: 1px solid black; padding: 0 2px;">192</span>	⋈ <span style="border: 1px solid black; padding: 0 2px;">208</span>	α <span style="border: 1px solid black; padding: 0 2px;">224</span>	≡ <span style="border: 1px solid black; padding: 0 2px;">240</span>
1	ü <span style="border: 1px solid black; padding: 0 2px;">129</span>	æ <span style="border: 1px solid black; padding: 0 2px;">145</span>	í <span style="border: 1px solid black; padding: 0 2px;">161</span>	 <span style="border: 1px solid black; padding: 0 2px;">177</span>	⊥ <span style="border: 1px solid black; padding: 0 2px;">193</span>	⌘ <span style="border: 1px solid black; padding: 0 2px;">209</span>	β <span style="border: 1px solid black; padding: 0 2px;">225</span>	± <span style="border: 1px solid black; padding: 0 2px;">241</span>
2	é <span style="border: 1px solid black; padding: 0 2px;">130</span>	Æ <span style="border: 1px solid black; padding: 0 2px;">146</span>	ó <span style="border: 1px solid black; padding: 0 2px;">162</span>	 <span style="border: 1px solid black; padding: 0 2px;">178</span>	⌞ <span style="border: 1px solid black; padding: 0 2px;">194</span>	⌠ <span style="border: 1px solid black; padding: 0 2px;">210</span>	Γ <span style="border: 1px solid black; padding: 0 2px;">226</span>	≥ <span style="border: 1px solid black; padding: 0 2px;">242</span>
3	â <span style="border: 1px solid black; padding: 0 2px;">131</span>	ô <span style="border: 1px solid black; padding: 0 2px;">147</span>	ú <span style="border: 1px solid black; padding: 0 2px;">163</span>	<span style="border: 1px solid black; padding: 0 2px;">179</span>	† <span style="border: 1px solid black; padding: 0 2px;">195</span>	⋈ <span style="border: 1px solid black; padding: 0 2px;">211</span>	π <span style="border: 1px solid black; padding: 0 2px;">227</span>	≤ <span style="border: 1px solid black; padding: 0 2px;">243</span>
4	ä <span style="border: 1px solid black; padding: 0 2px;">132</span>	ö <span style="border: 1px solid black; padding: 0 2px;">148</span>	ñ <span style="border: 1px solid black; padding: 0 2px;">164</span>	¡ <span style="border: 1px solid black; padding: 0 2px;">180</span>	- <span style="border: 1px solid black; padding: 0 2px;">196</span>	⌘ <span style="border: 1px solid black; padding: 0 2px;">212</span>	Σ <span style="border: 1px solid black; padding: 0 2px;">228</span>	∫ <span style="border: 1px solid black; padding: 0 2px;">244</span>
5	à <span style="border: 1px solid black; padding: 0 2px;">133</span>	ò <span style="border: 1px solid black; padding: 0 2px;">149</span>	Ñ <span style="border: 1px solid black; padding: 0 2px;">165</span>	‡ <span style="border: 1px solid black; padding: 0 2px;">181</span>	‡ <span style="border: 1px solid black; padding: 0 2px;">197</span>	⌘ <span style="border: 1px solid black; padding: 0 2px;">213</span>	σ <span style="border: 1px solid black; padding: 0 2px;">229</span>	⋈ <span style="border: 1px solid black; padding: 0 2px;">245</span>
6	â <span style="border: 1px solid black; padding: 0 2px;">134</span>	û <span style="border: 1px solid black; padding: 0 2px;">150</span>	á <span style="border: 1px solid black; padding: 0 2px;">166</span>	‡ <span style="border: 1px solid black; padding: 0 2px;">182</span>	‡ <span style="border: 1px solid black; padding: 0 2px;">198</span>	⌘ <span style="border: 1px solid black; padding: 0 2px;">214</span>	μ <span style="border: 1px solid black; padding: 0 2px;">230</span>	÷ <span style="border: 1px solid black; padding: 0 2px;">246</span>
7	ç <span style="border: 1px solid black; padding: 0 2px;">135</span>	ù <span style="border: 1px solid black; padding: 0 2px;">151</span>	ó <span style="border: 1px solid black; padding: 0 2px;">167</span>	⌘ <span style="border: 1px solid black; padding: 0 2px;">183</span>	‡ <span style="border: 1px solid black; padding: 0 2px;">199</span>	‡ <span style="border: 1px solid black; padding: 0 2px;">215</span>	τ <span style="border: 1px solid black; padding: 0 2px;">231</span>	≈ <span style="border: 1px solid black; padding: 0 2px;">247</span>
8	ê <span style="border: 1px solid black; padding: 0 2px;">136</span>	ÿ <span style="border: 1px solid black; padding: 0 2px;">152</span>	¿ <span style="border: 1px solid black; padding: 0 2px;">168</span>	‡ <span style="border: 1px solid black; padding: 0 2px;">184</span>	⋈ <span style="border: 1px solid black; padding: 0 2px;">200</span>	‡ <span style="border: 1px solid black; padding: 0 2px;">216</span>	Φ <span style="border: 1px solid black; padding: 0 2px;">232</span>	° <span style="border: 1px solid black; padding: 0 2px;">248</span>
9	ë <span style="border: 1px solid black; padding: 0 2px;">137</span>	Ö <span style="border: 1px solid black; padding: 0 2px;">153</span>	⌘ <span style="border: 1px solid black; padding: 0 2px;">169</span>	‡ <span style="border: 1px solid black; padding: 0 2px;">185</span>	⌘ <span style="border: 1px solid black; padding: 0 2px;">201</span>	⌘ <span style="border: 1px solid black; padding: 0 2px;">217</span>	Θ <span style="border: 1px solid black; padding: 0 2px;">233</span>	• <span style="border: 1px solid black; padding: 0 2px;">249</span>
A	è <span style="border: 1px solid black; padding: 0 2px;">138</span>	Ü <span style="border: 1px solid black; padding: 0 2px;">154</span>	⌘ <span style="border: 1px solid black; padding: 0 2px;">170</span>	‡ <span style="border: 1px solid black; padding: 0 2px;">186</span>	⋈ <span style="border: 1px solid black; padding: 0 2px;">202</span>	⌘ <span style="border: 1px solid black; padding: 0 2px;">218</span>	Ω <span style="border: 1px solid black; padding: 0 2px;">234</span>	· <span style="border: 1px solid black; padding: 0 2px;">250</span>
B	ï <span style="border: 1px solid black; padding: 0 2px;">139</span>	ø <span style="border: 1px solid black; padding: 0 2px;">155</span>	½ <span style="border: 1px solid black; padding: 0 2px;">171</span>	‡ <span style="border: 1px solid black; padding: 0 2px;">187</span>	⌘ <span style="border: 1px solid black; padding: 0 2px;">203</span>	■ <span style="border: 1px solid black; padding: 0 2px;">219</span>	δ <span style="border: 1px solid black; padding: 0 2px;">235</span>	√ <span style="border: 1px solid black; padding: 0 2px;">251</span>
C	î <span style="border: 1px solid black; padding: 0 2px;">140</span>	£ <span style="border: 1px solid black; padding: 0 2px;">156</span>	¼ <span style="border: 1px solid black; padding: 0 2px;">172</span>	‡ <span style="border: 1px solid black; padding: 0 2px;">188</span>	‡ <span style="border: 1px solid black; padding: 0 2px;">204</span>	■ <span style="border: 1px solid black; padding: 0 2px;">220</span>	∞ <span style="border: 1px solid black; padding: 0 2px;">236</span>	∞ <span style="border: 1px solid black; padding: 0 2px;">252</span>
D	ì <span style="border: 1px solid black; padding: 0 2px;">141</span>	Ø <span style="border: 1px solid black; padding: 0 2px;">157</span>	ì <span style="border: 1px solid black; padding: 0 2px;">173</span>	‡ <span style="border: 1px solid black; padding: 0 2px;">189</span>	= <span style="border: 1px solid black; padding: 0 2px;">205</span>	■ <span style="border: 1px solid black; padding: 0 2px;">221</span>	φ <span style="border: 1px solid black; padding: 0 2px;">237</span>	² <span style="border: 1px solid black; padding: 0 2px;">253</span>
E	Ä <span style="border: 1px solid black; padding: 0 2px;">142</span>	ŕ <span style="border: 1px solid black; padding: 0 2px;">158</span>	« <span style="border: 1px solid black; padding: 0 2px;">174</span>	‡ <span style="border: 1px solid black; padding: 0 2px;">190</span>	‡ <span style="border: 1px solid black; padding: 0 2px;">206</span>	■ <span style="border: 1px solid black; padding: 0 2px;">222</span>	€ <span style="border: 1px solid black; padding: 0 2px;">238</span>	■ <span style="border: 1px solid black; padding: 0 2px;">254</span>
F	Å <span style="border: 1px solid black; padding: 0 2px;">143</span>	f <span style="border: 1px solid black; padding: 0 2px;">159</span>	¤ <span style="border: 1px solid black; padding: 0 2px;">175</span>	‡ <span style="border: 1px solid black; padding: 0 2px;">191</span>	⋈ <span style="border: 1px solid black; padding: 0 2px;">207</span>	■ <span style="border: 1px solid black; padding: 0 2px;">223</span>	∩ <span style="border: 1px solid black; padding: 0 2px;">239</span>	SP <span style="border: 1px solid black; padding: 0 2px;">255</span>

# ESC/POS Mode

Page 255 (Space Page)

Hexa- decimal	8	9	A	B	C	D	E	F
0	SP 128	SP 144	SP 160	SP 176	SP 192	SP 208	SP 224	SP 240
1	SP 129	SP 145	SP 161	SP 177	SP 193	SP 209	SP 225	SP 241
2	SP 130	SP 146	SP 162	SP 178	SP 194	SP 210	SP 226	SP 242
3	SP 131	SP 147	SP 163	SP 179	SP 195	SP 211	SP 227	SP 243
4	SP 132	SP 148	SP 164	SP 180	SP 196	SP 212	SP 228	SP 244
5	SP 133	SP 149	SP 165	SP 181	SP 197	SP 213	SP 229	SP 245
6	SP 134	SP 150	SP 166	SP 182	SP 198	SP 214	SP 230	SP 246
7	SP 135	SP 151	SP 167	SP 183	SP 199	SP 215	SP 231	SP 247
8	SP 136	SP 152	SP 168	SP 184	SP 200	SP 216	SP 232	SP 248
9	SP 137	SP 153	SP 169	SP 185	SP 201	SP 217	SP 233	SP 249
A	SP 138	SP 154	SP 170	SP 186	SP 202	SP 218	SP 234	SP 250
B	SP 139	SP 155	SP 171	SP 187	SP 203	SP 219	SP 235	SP 251
C	SP 140	SP 156	SP 172	SP 188	SP 204	SP 220	SP 236	SP 252
D	SP 141	SP 157	SP 173	SP 189	SP 205	SP 221	SP 237	SP 253
E	SP 142	SP 158	SP 174	SP 190	SP 206	SP 222	SP 238	SP 254
F	SP 143	SP 159	SP 175	SP 191	SP 207	SP 223	SP 239	SP 255

# ESC/POS Mode

## International Character Set

	35	36	64	91	92	93	94	96	123	124	125	126
U. S. A.	#	\$	@	[	\	]	^	`	{		}	~
France	#	\$	à	°	ç	§	^	`	é	ù	è	¨
Germany	#	\$	§	Ä	Ö	Ü	^	`	ä	ö	ü	ß
England	£	\$	@	[	\	]	^	`	{		}	~
Denmark 1	#	\$	@	Æ	Ø	Å	^	`	æ	ø	å	~
Sweden	#	¤	É	Ä	Ö	Å	Ü	é	ä	ö	å	ü
Italy	#	\$	@	°	\	é	^	ù	à	ò	è	ì
Spain	₧	\$	@	ı	Ñ	¿	^	'	¨	ñ	}	~
Japan	#	\$	@	[	¥	]	^	`	{		}	~
Norway	#	¤	É	Æ	Ø	Å	Ü	é	æ	ø	å	ü
Denmark 2	#	\$	É	Æ	Ø	Å	Ü	é	æ	ø	å	ü

## 11. AUTOMATIC CUTTER

The TSP242 comes equipped with a guillotine-type automatic paper cutter.

- ① The cutter operates in response to data commands. To enable cutter operation, set Memory Switch #2-8 to indicate that the cutter is installed.
- ② NEVER place fingers or metal objects in the cutter area.
- ③ If a jam occurs in the cutter area, switch off the power, use tweezers to remove the jammed paper, then switch the power back on. The printer will return the blade to the home position.
- ④ Never clean the cutter blade with alcohol or any other solvent, as this may remove the blade's lubrication and shorten the blade life.

# MEMO





**ELECTRONIC PRODUCTS DIVISION  
STAR MICRONICS CO., LTD.**

536 Nanatsushinnya, Shimizu, Shizuoka, 424 Japan  
Tel: 0543-47-0112, Fax: 0543-48-5271

**OVERSEAS SUBSIDIARY COMPANIES  
STAR MICRONICS AMERICA, INC.**

70-D Ethel Road West, Piscataway, NJ 08854 U.S.A  
Tel: 908-572-9512, Fax: 908-572-5095

**STAR MICRONICS DEUTSCHLAND GMBH**

Westerbachstraße 59, D-60489 Frankfurt, Germany  
Tel: 069-789990, Fax: 069-781006

**STAR MICRONICS U.K. LTD.**

Star House, Peregrine Business Park, Gomm Road,  
High Wycombe, Bucks, HP13 7DL, U.K.  
Tel: 01494-471111, Fax: 01494-473333